

# YOUTH BIBLE LESSONS

LEVEL

2

[www.cog.org](http://www.cog.org)



Creation



Adam & Eve



Cain & Abel



Noah and the Flood

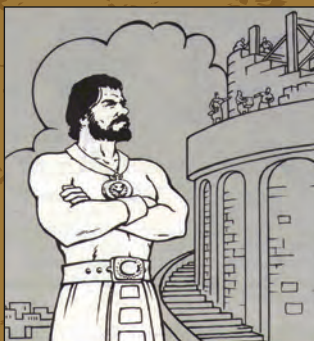

Nimrod and the  
Tower of Babel



Abraham Obeys God



Esau and Jacob



Jacob and His Family



Joseph's Adventures  
in Egypt



Moses Is Called By God



God Sends Plagues  
Upon Egypt



The Spring & Fall Feasts

---

# YOUTH

---

LEVEL 2

---

# BIBLE

---

# LESSONS

---

LESSON 1

---

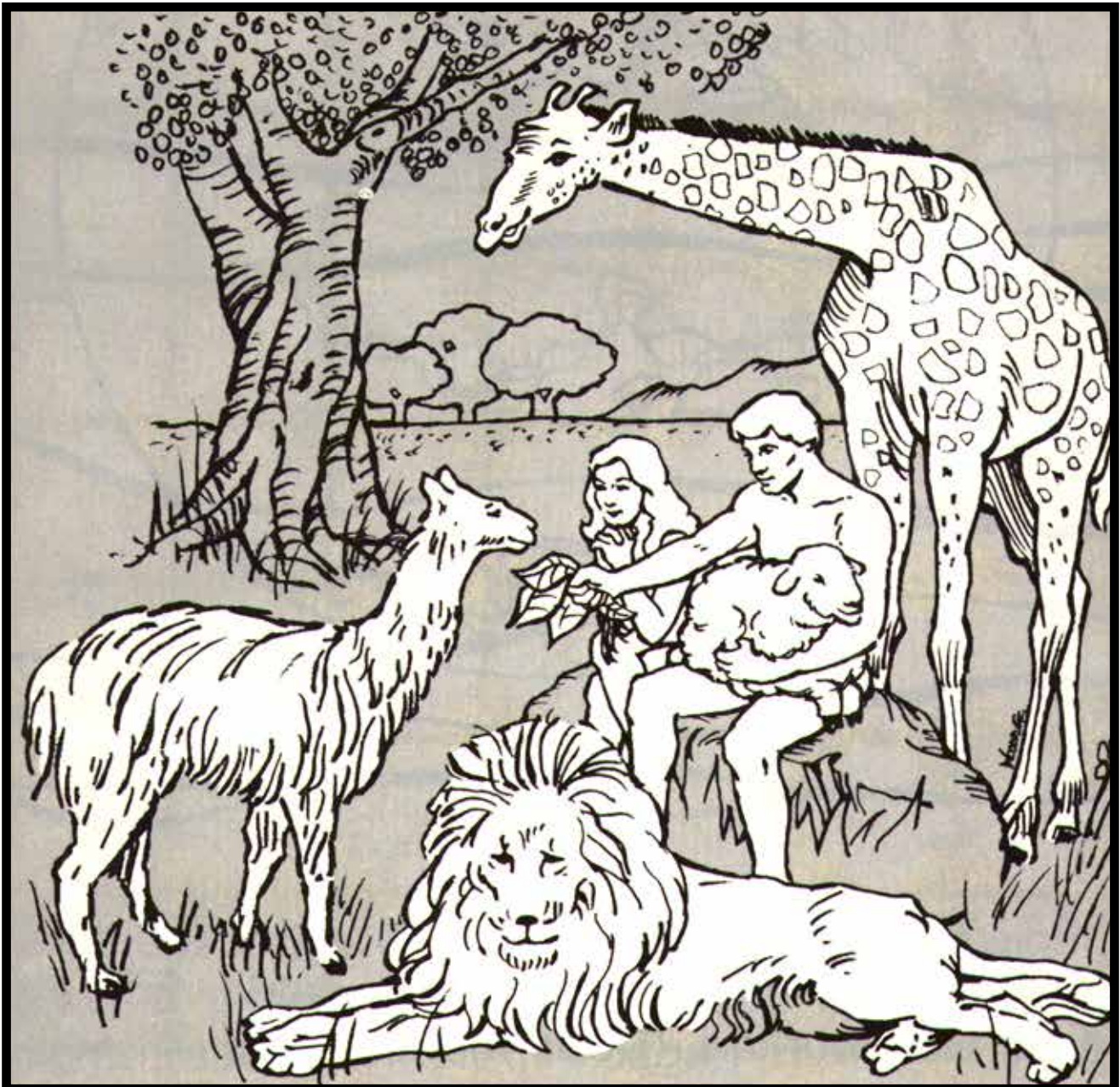

Creation

---

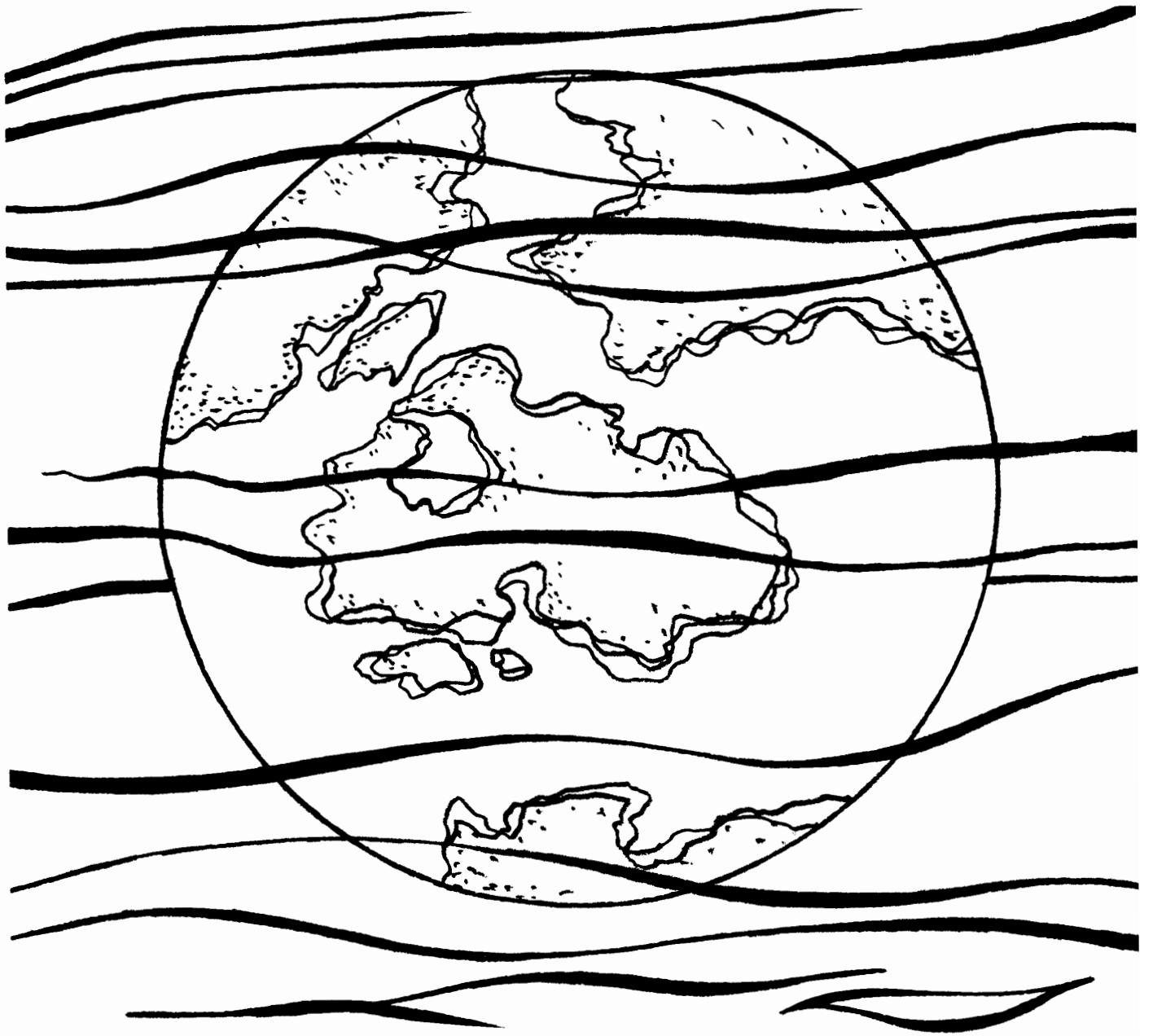

In the beginning God made the world. For six days God worked. (Color the picture.)

Illustrations by Michael Jon Woodruff

On the first day God made the day and the night.  
(Find a picture showing day and one showing  
night. Paste them on this page.)

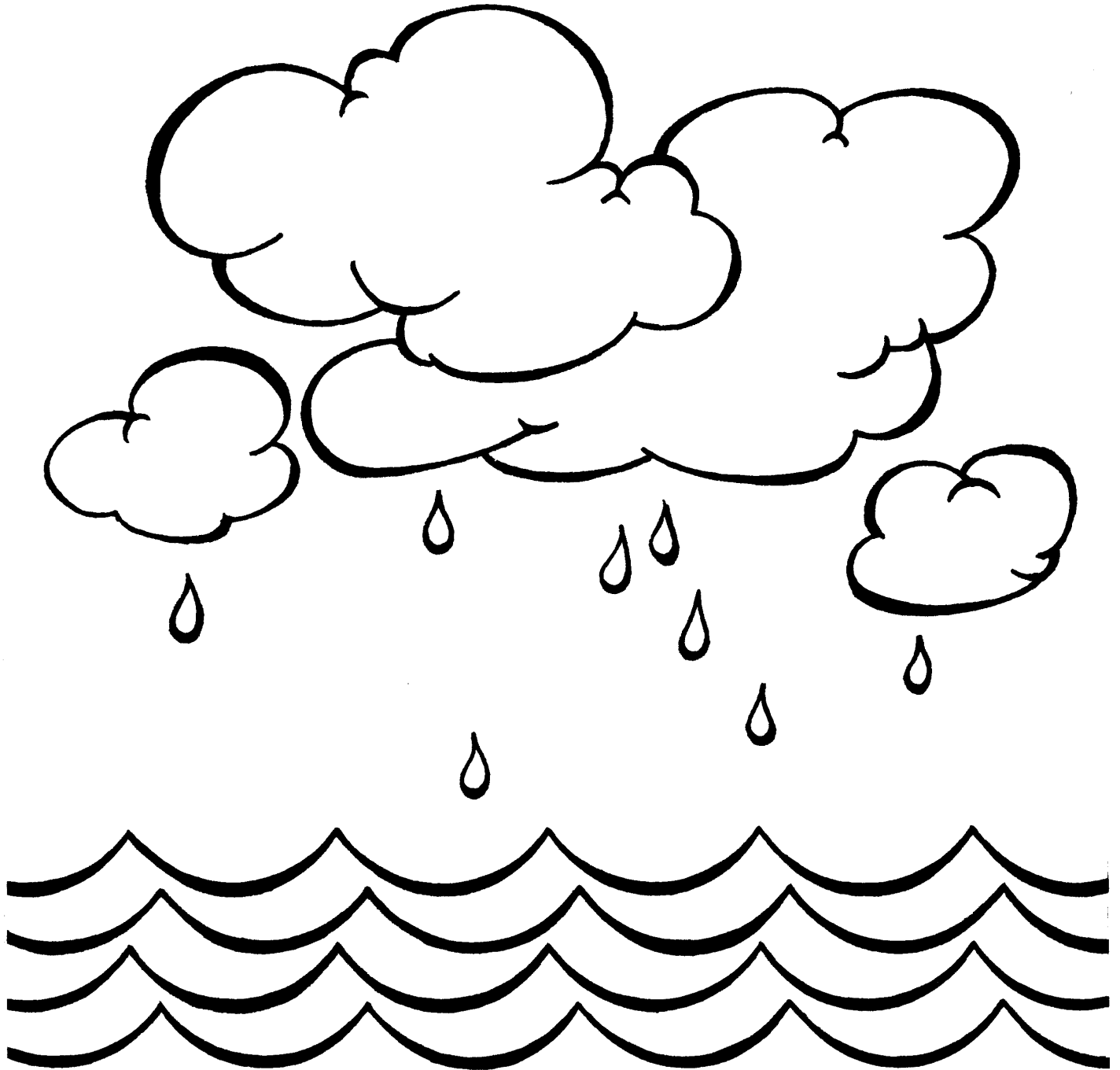

On the second day God made the air we breathe by dividing the waters above the earth from the waters under the earth. (Color the picture.)

**On the third day God made the land, seas, plants and trees. (Find pictures of these and paste them on this page.)**



On the fourth day God caused the sun, moon and stars to become visible. (Color the picture.)

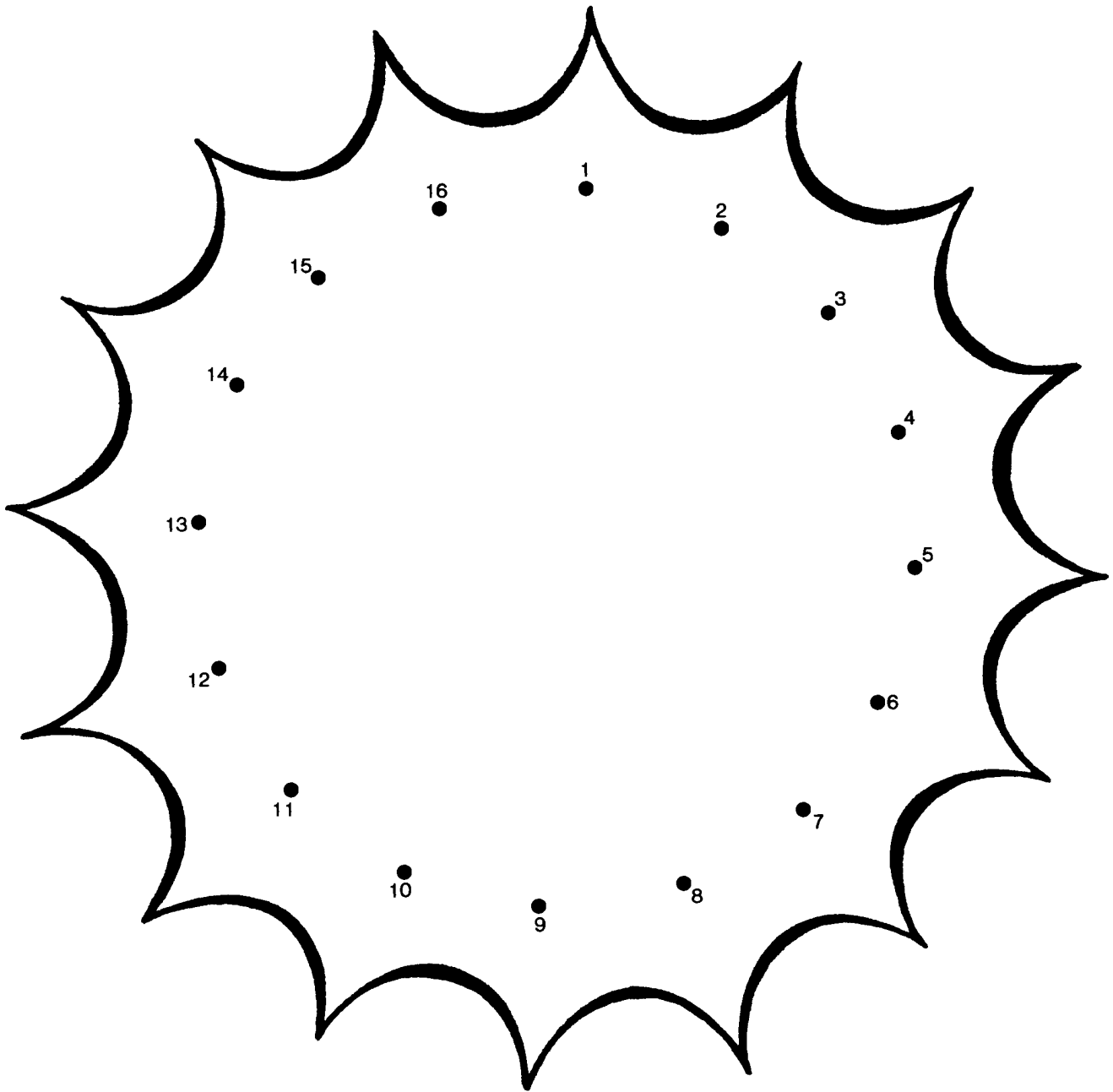

Connect the dots to find what God caused to become visible on the fourth day.



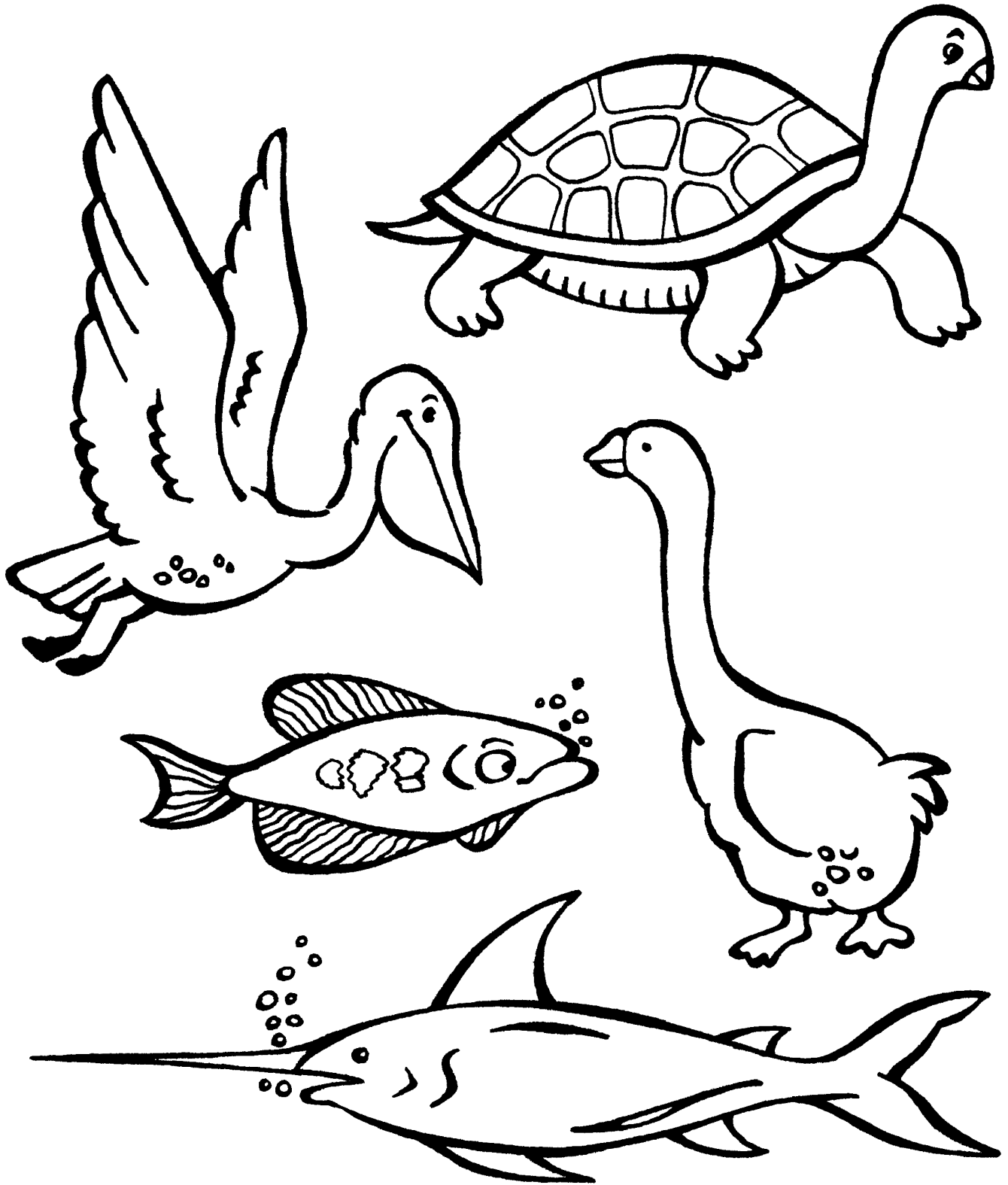

On the fifth day God made the birds and the sea animals. (Color the picture.)

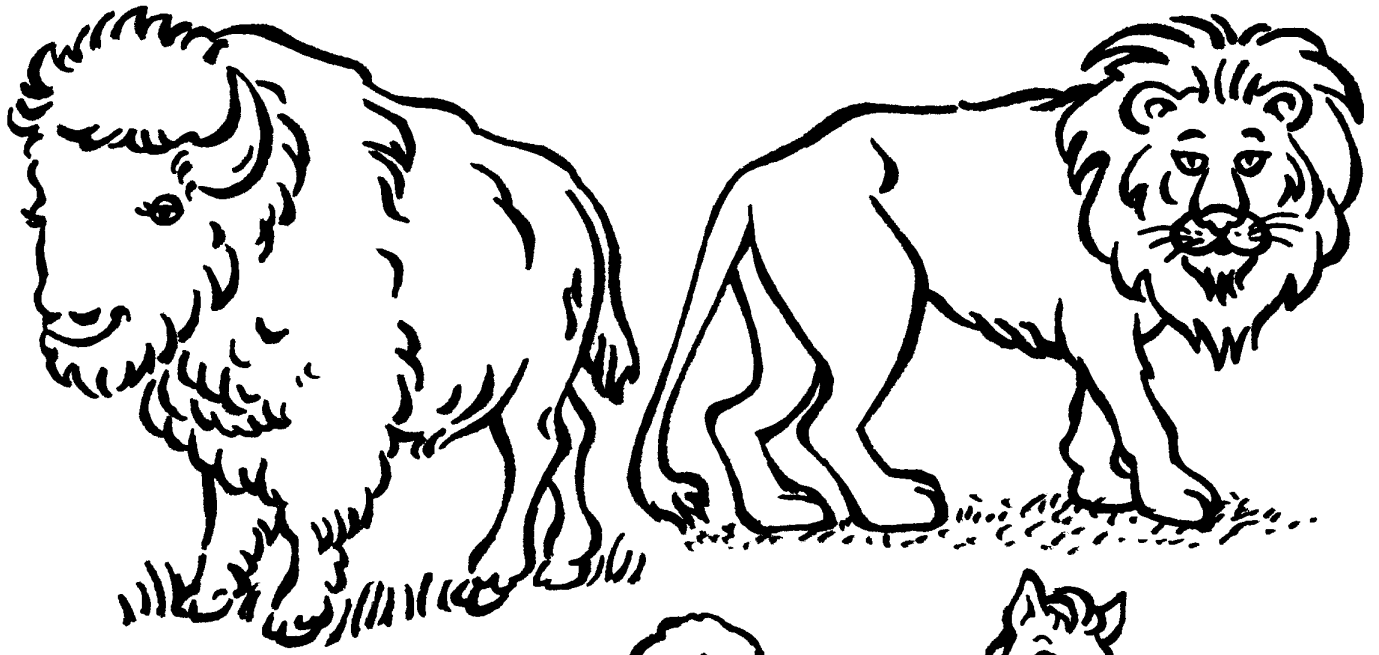

On the sixth day God made the land animals and man. (Color only the land animals.)

On the seventh day God made the Sabbath by resting. He made this day holy. This is the same Sabbath we keep today. (Find a picture of someone resting and paste it on this page.)

**Day**

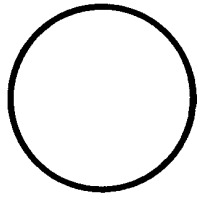

sun, moon, stars

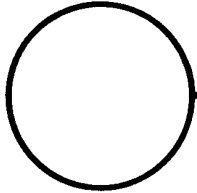

land, seas,  
plants, trees

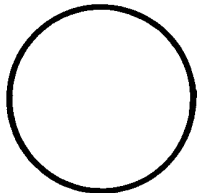

*Sabbath*

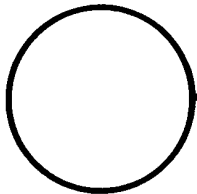

land animals,  
man

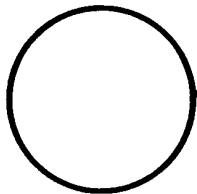
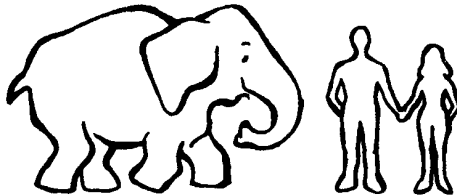

air we breathe

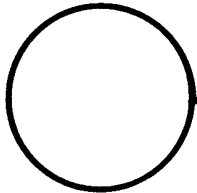

day, night

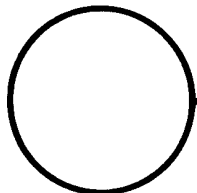
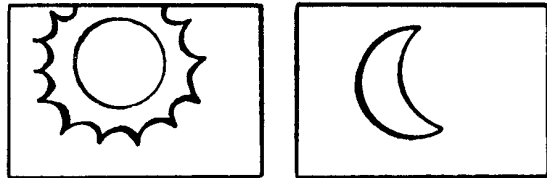

sea animals,  
birds



**The 7 Days of Creation**

(In each circle write the number of the day on which the pictured events took place.)

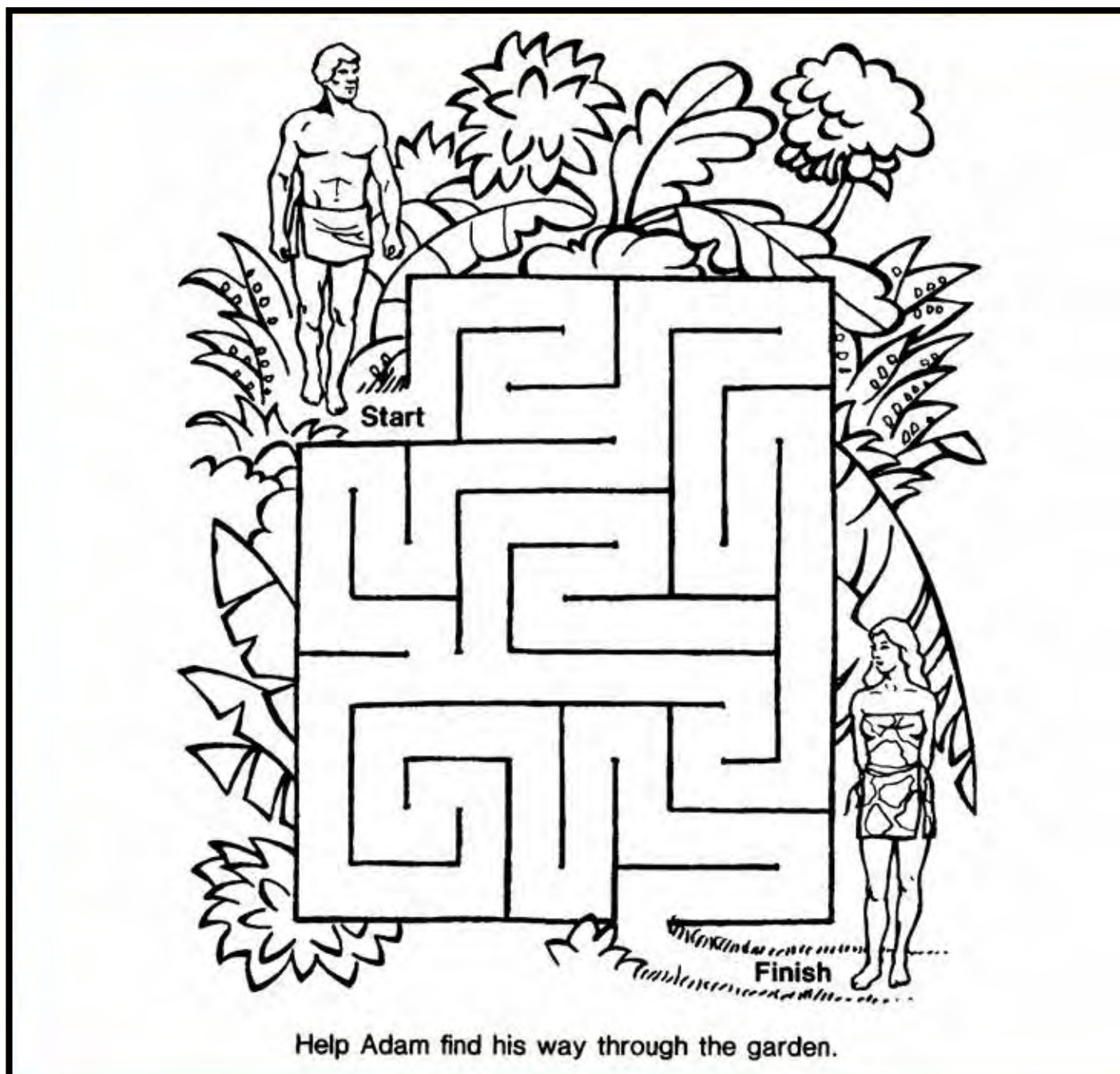

Help Adam find his way through the garden.

---

# YOUTH

---

LEVEL 2

---

# BIBLE

---

# LESSONS

---

LESSON 2

---

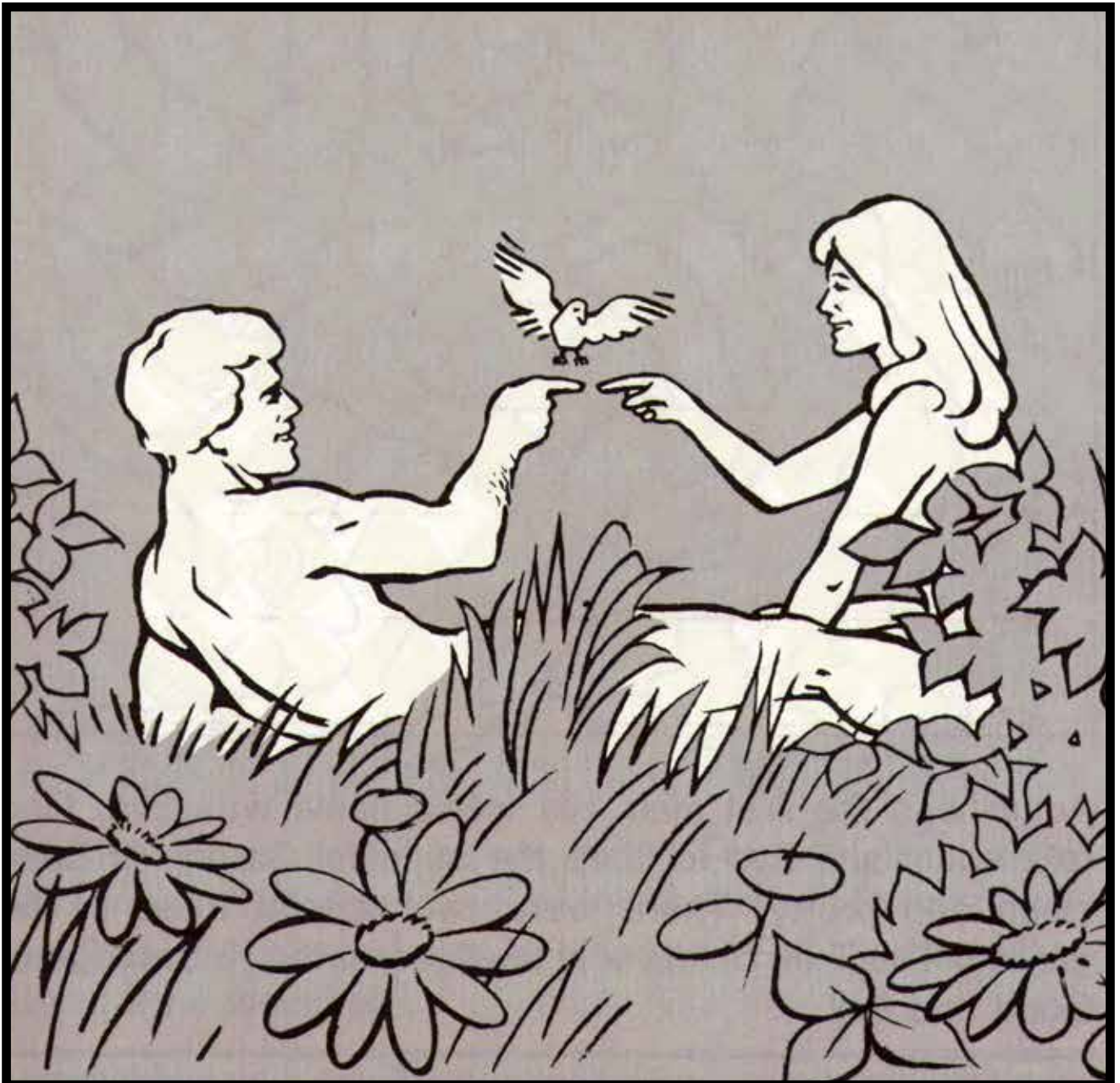

Adam and Eve

---

# ADAM AND EVE

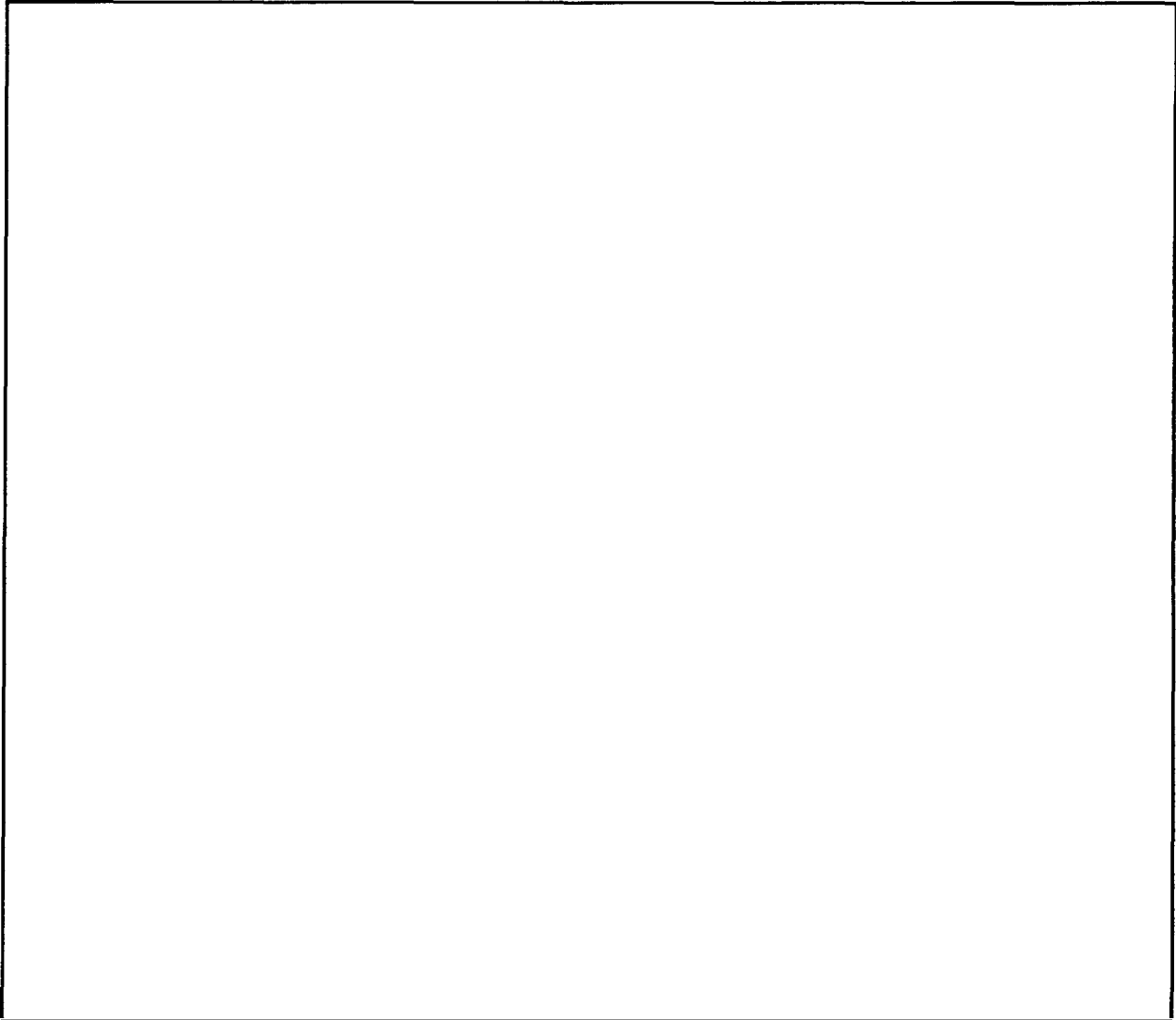

Adam was the first man. His wife's name was Eve. God told Adam and Eve to keep the beautiful Garden of Eden clean and pretty. There were two special trees in the garden. The Tree of Life and the Tree of the Knowledge of Good and Evil.

---

Parents: In simple terms you may wish to show your child on a map or globe generally where the Garden of Eden was. In the space above, have your child draw a picture of what he thinks the Garden of Eden may have looked like. Also, the pictures in this lesson are for your child to color. Also tell them that scientists admit that all humans came from one mother. The Bible says her name was Eve.



God told Adam that if he ate of the Tree of Life he could live forever. The only tree God told Adam not to eat of was the Tree of the Knowledge of Good and Evil. God said if he ate of it he would die.

---

Parents: Explain that God didn't mean they would immediately die but that they wouldn't live forever.





Satan did not want Adam and Eve to trust God, so he told them a **lie**. He said they would not die if they ate of the Tree of the Knowledge of Good and Evil. Satan said it would help them be wise like God.



Adam chose the wrong way by eating the fruit of the Tree of the Knowledge of Good and Evil instead of the Tree of Life. This was man's first **sin** because he disobeyed what God said.

---

Parents: Ask your child to tell you what he thinks sin is. How has he broken God's commandments? Let him come up with the ways.

From this time on people began to think the wrong way was the right way. This is the way the world thinks today. This is why they are not happy. Satan has made the world love his wrong ways.

---

Parents: Have your child find pictures of unhappy people or things that make him unhappy and paste them on this page.

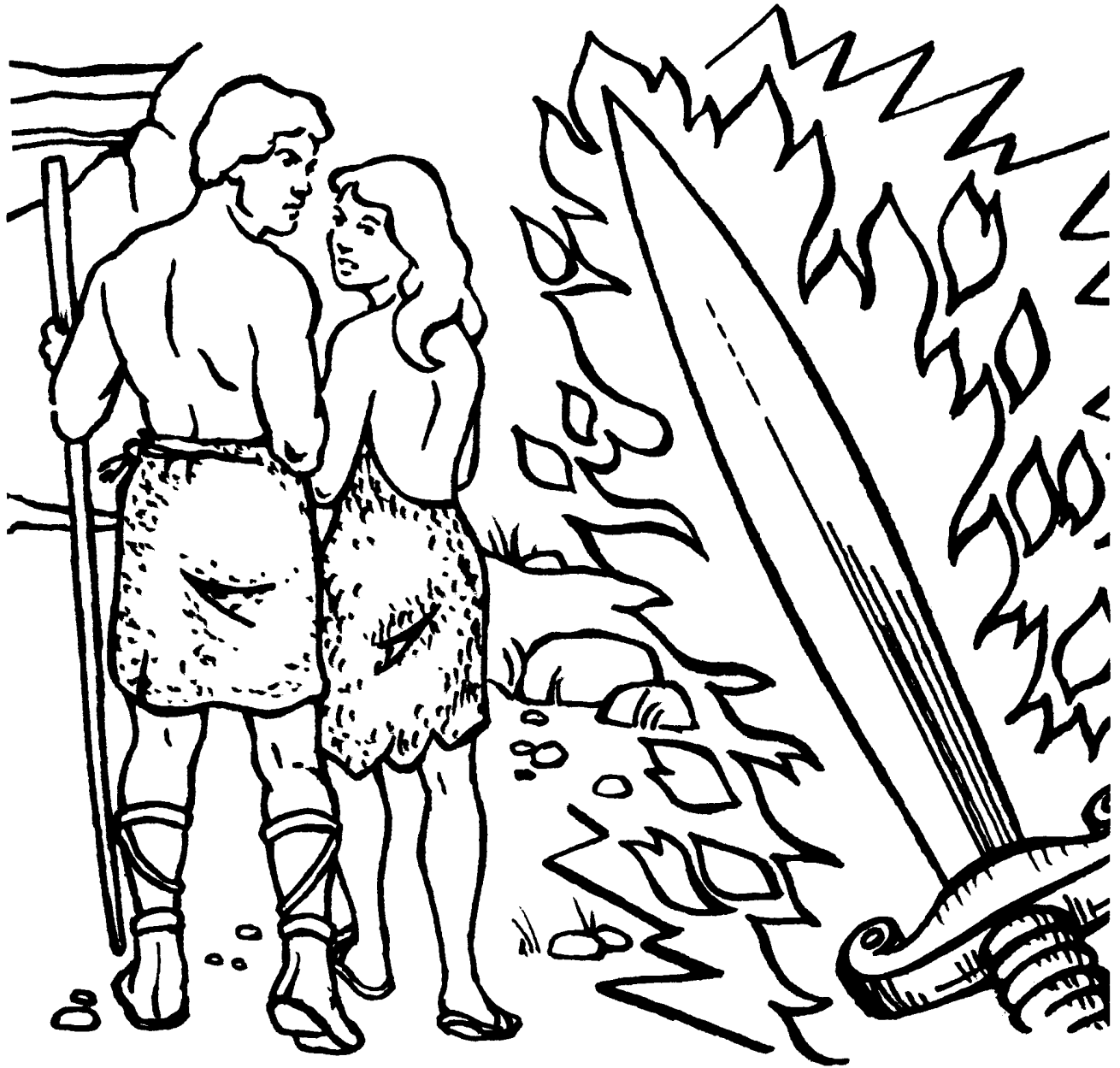

God knew Adam and Eve would be unhappy since they did not choose to eat of the Tree of Life. He told them they could not stay in the beautiful Garden. He put angels and a flaming sword at the gate to keep them out.

---

Parents: Explain why God kept Adam and Eve out of the Garden of Eden.

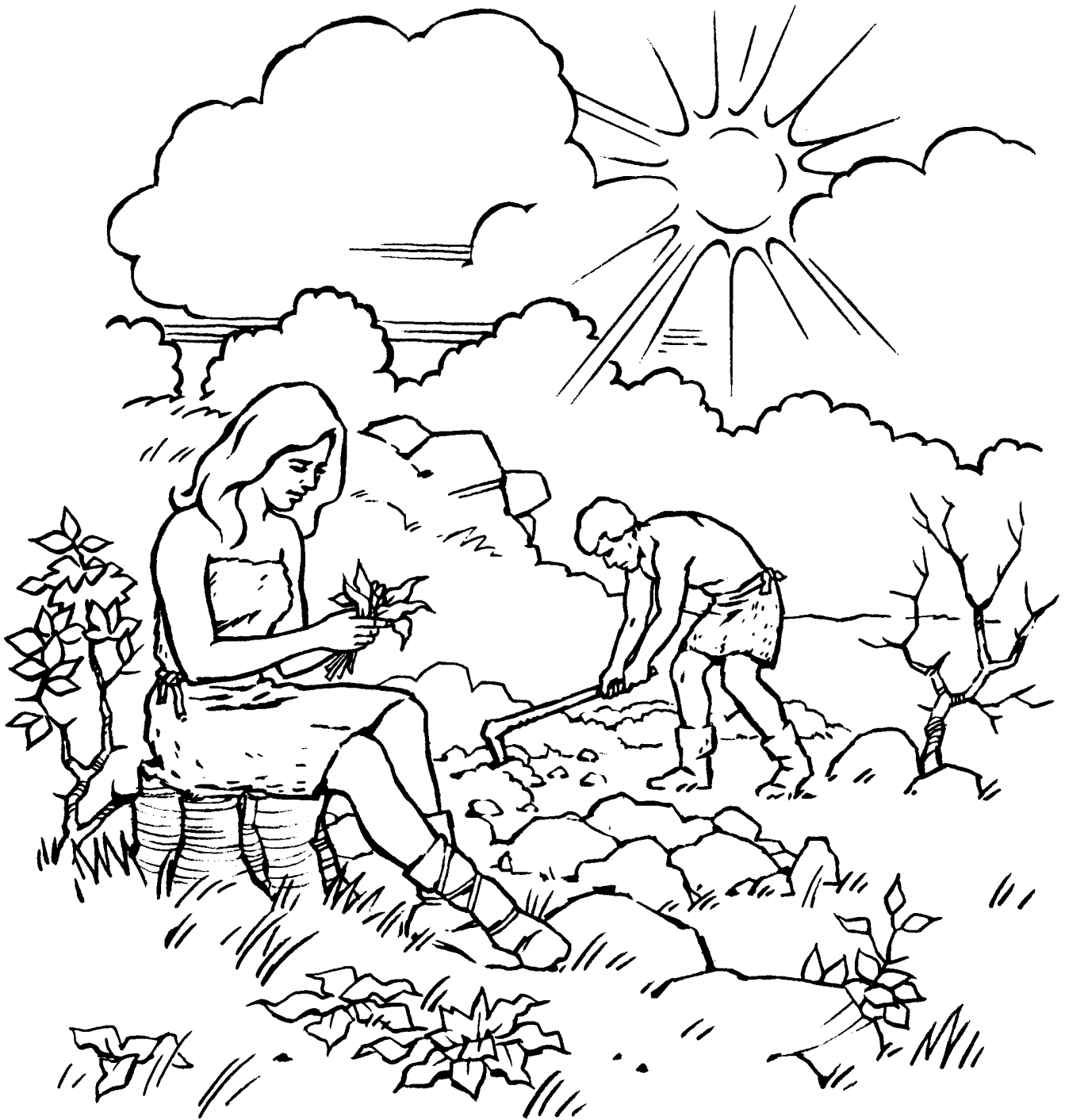

Now Adam and Eve were very sad. They were alone. Now they would have to work hard for their food. They did not have a beautiful garden to enjoy.

---

Parents: Prompt discussion with such questions as: How was Adam and Eve's life different now?

# Word Search

Find in the puzzle the words that are listed. Words are written across and down—some forward and some backward—or they may be at an angle. Circle the words in the puzzle and cross them off the list.

<b>ANIMALS</b>	<b>G</b>	<b>D</b>	<b>F</b>	<b>K</b>	<b>J</b>	<b>Z</b>	<b>N</b>	<b>M</b>
<b>GARDEN</b>	<b>J</b>	<b>A</b>	<b>E</b>	<b>V</b>	<b>E</b>	<b>N</b>	<b>S</b>	<b>T</b>
<b>ADAM</b>	<b>X</b>	<b>D</b>	<b>R</b>	<b>C</b>	<b>E</b>	<b>B</b>	<b>P</b>	<b>A</b>
<b>EVE</b>	<b>P</b>	<b>A</b>	<b>R</b>	<b>D</b>	<b>I</b>	<b>F</b>	<b>G</b>	<b>K</b>
<b>EDEN</b>	<b>S</b>	<b>M</b>	<b>E</b>	<b>T</b>	<b>E</b>	<b>L</b>	<b>M</b>	<b>J</b>
	<b>S</b>	<b>L</b>	<b>A</b>	<b>M</b>	<b>I</b>	<b>N</b>	<b>A</b>	<b>O</b>
	<b>T</b>	<b>A</b>	<b>B</b>	<b>N</b>	<b>D</b>	<b>H</b>	<b>P</b>	<b>Q</b>
	<b>L</b>	<b>C</b>	<b>M</b>	<b>Q</b>	<b>T</b>	<b>V</b>	<b>U</b>	<b>E</b>

---

Parents: Please explain these directions for this first word search. Have your child find the given words in the puzzle. Words may be written across, down, forward, backward, or diagonally. After you circle each word, cross it off the list. See the example.

# QUESTIONS

1. Who was the first man? \_\_\_\_\_.
2. What did God put at the gate of the Garden to keep Adam and Eve out? \_\_\_\_\_  
\_\_\_\_\_.
3. What tree did God tell Adam and Eve not to eat of?  
\_\_\_\_\_  
\_\_\_\_\_.

## Answers

ANGELS AND A SWORD  
ADAM  
TREE OF THE KNOWLEDGE  
OF GOOD AND EVIL

# Crossword Puzzle

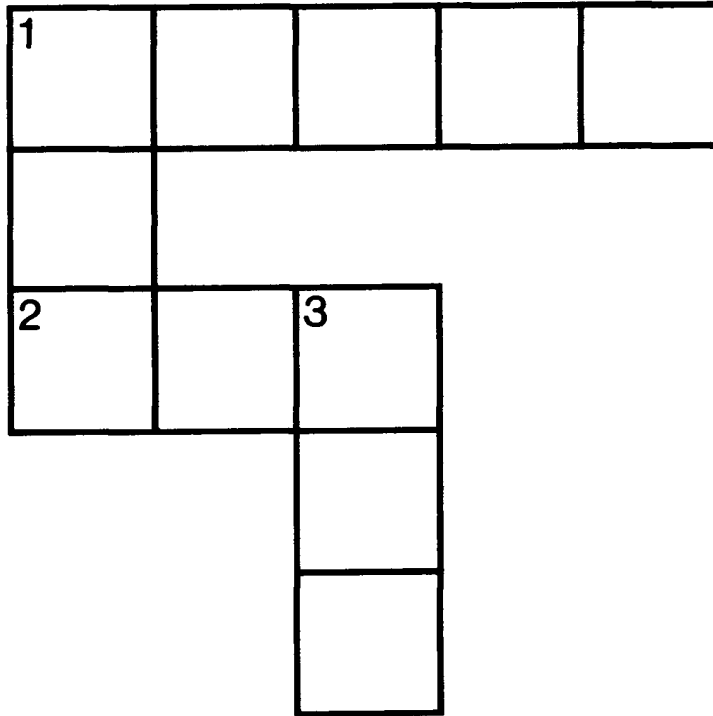

## Across

1. \_\_\_\_\_ did not want Adam and Eve to trust God.
2. God told Adam and Eve they would \_\_\_\_\_ if they ate of the Tree of the Knowledge of Good and Evil.

## Down

1. The sin made Adam and Eve feel \_\_\_\_\_.
3. \_\_\_\_\_ first ate the fruit of the Tree of the Knowledge of Good and Evil.

SAD      SATAN      DIE      EVE



**BIBLE MEMORY**

Books of the  
 Old Testament

Genesis  
 Exodus  
 Leviticus  
 Numbers  
 Deuteronomy  
 Joshua  
 Judges

Ruth  
 1 Samuel (1 Kings)  
 2 Samuel (2 Kings)  
 1 Kings (3 Kings)  
 2 Kings (4 Kings)  
 1 Chronicles  
 2 Chronicles

Ezra  
 Nehemiah  
 Esther  
 Job  
 Psalms  
 Proverbs  
 Ecclesiastes

Song of Solomon  
 Isaiah  
 Jeremiah  
 Lamentations  
 Ezekiel  
 Daniel  
 Hosea

Joel  
 Amos  
 Obadiah  
 Jonah  
 Micah  
 Nahum  
 Habakkuk

Zephaniah  
 Haggai  
 Zechariah  
 Malachi

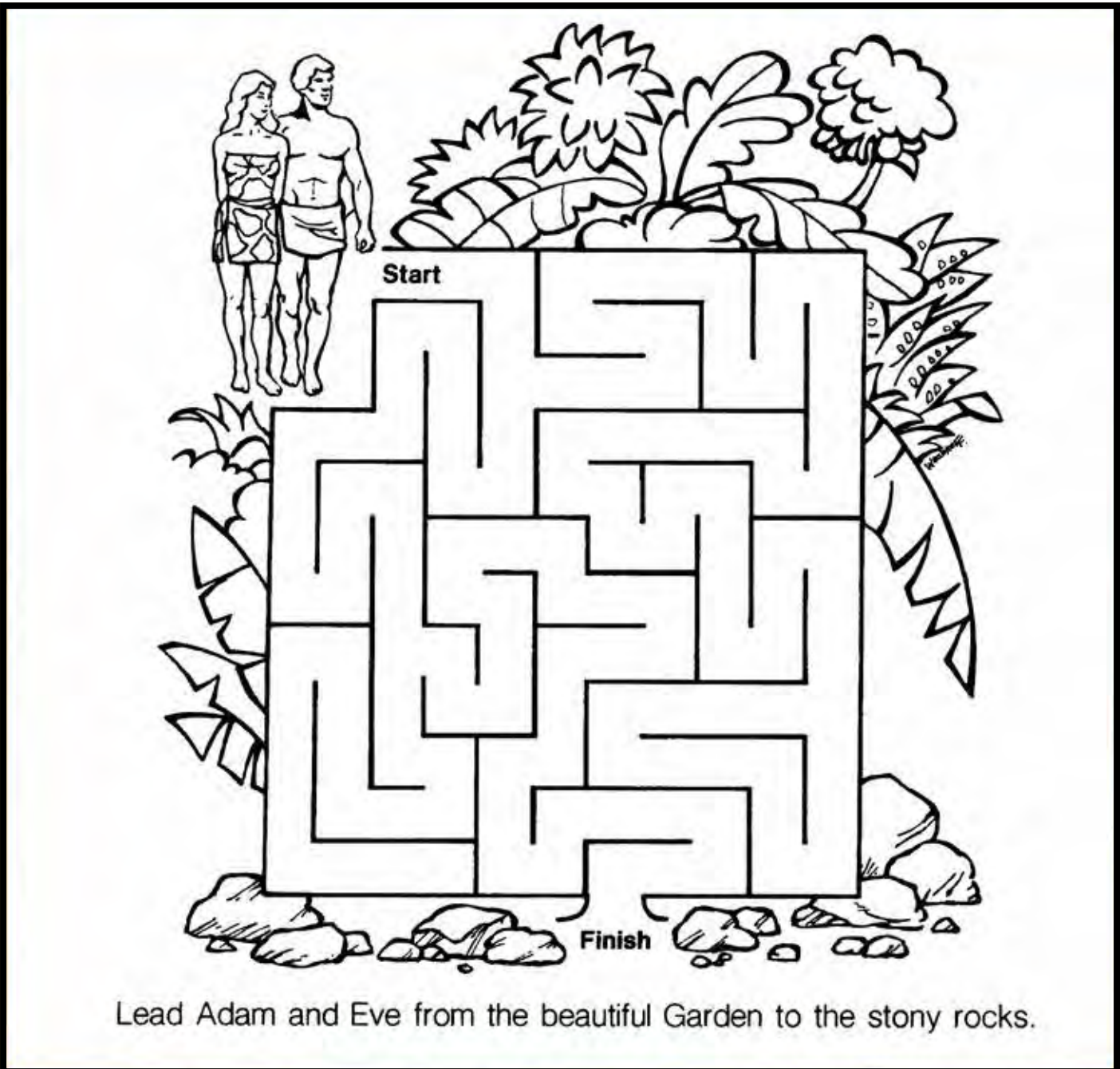

Lead Adam and Eve from the beautiful Garden to the stony rocks.

---

# YOUTH

---

LEVEL 2

# BIBLE

---

# LESSONS

---

LESSON 3

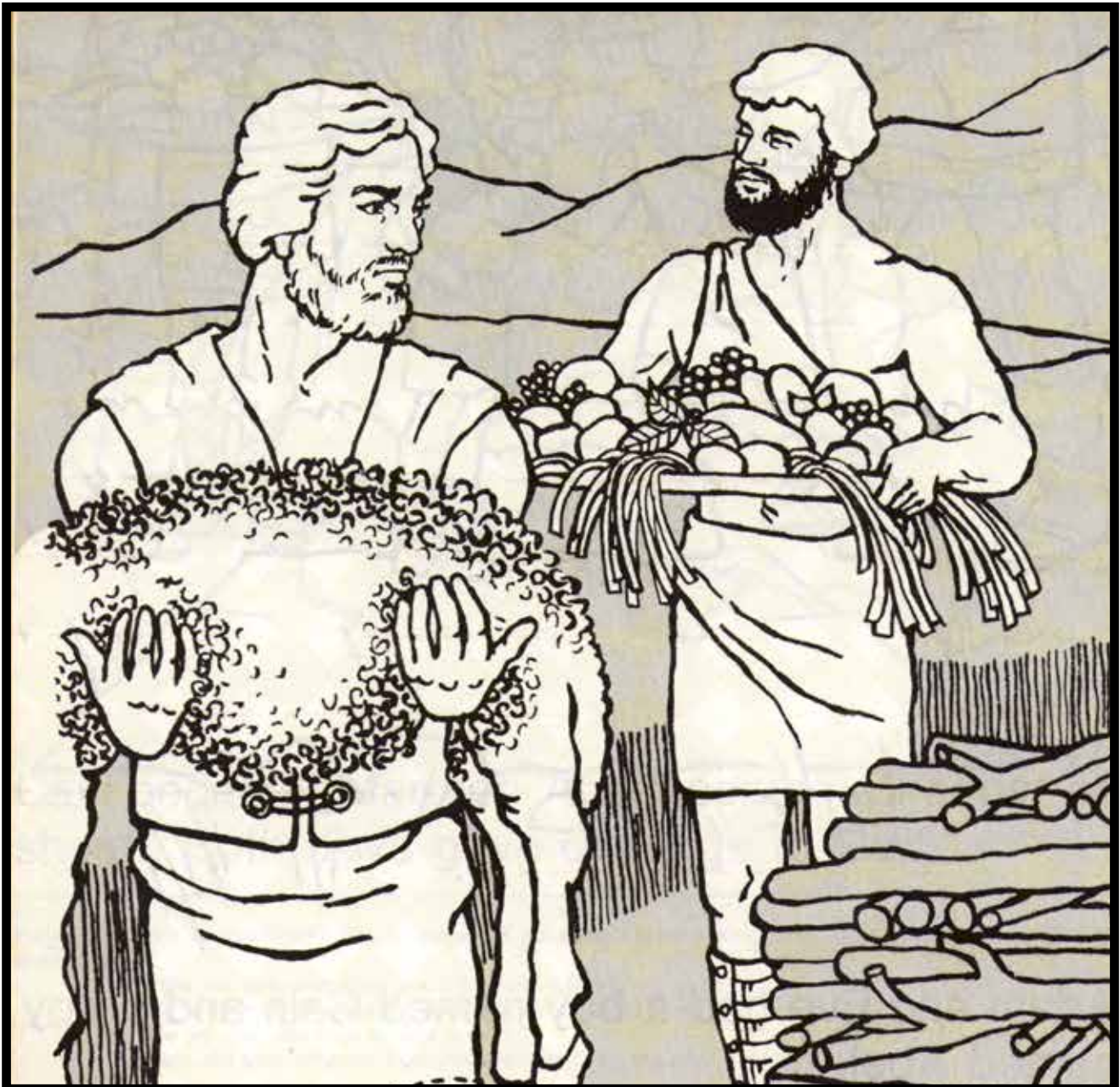

Cain & Abel

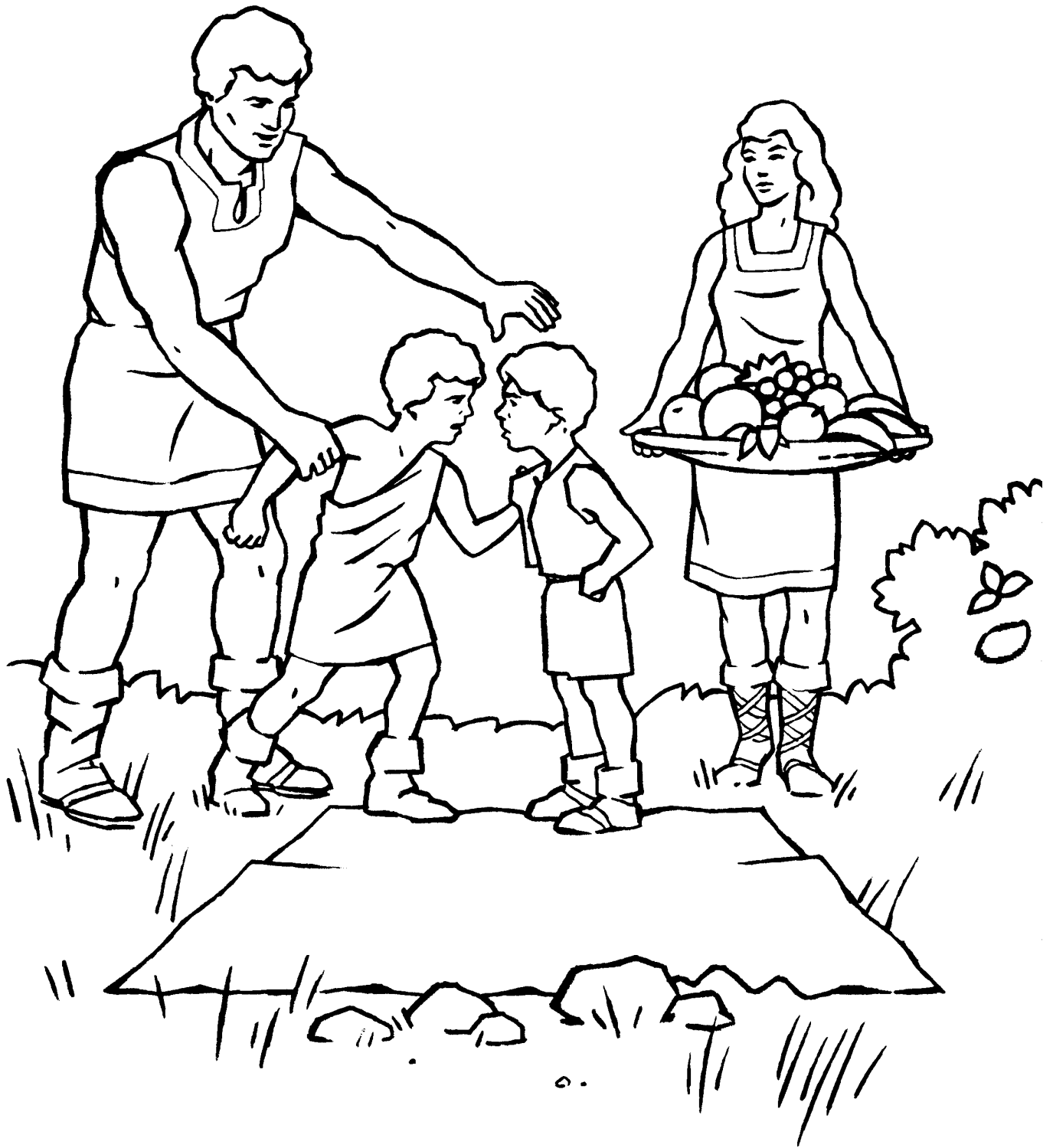

Adam and Eve had a boy named Cain and a boy named Abel.

---



Cain became a farmer. Abel became a keeper of sheep. Both boys gave offerings to God.

---

Parents: Explain to your child that a keeper of sheep is called a shepherd. Then discuss the following questions:

- How did Cain and Abel give offerings to God?
- What kind of offerings did Cain and Abel give to God?
- Do we give offerings to God today?
- How are they different from the offerings Cain and Abel gave?



Abel gave God a little lamb he loved very much. This little lamb was the best one he had. God was pleased with the offering Abel gave.

---

Parents: Ask your child this question:  
Why was God pleased with Abel's offering?

---



Cain had a little lamb, too. He didn't think he should give it to God, so he offered some of his vegetables. God was not pleased with Cain's offering.

---

Parents: Ask your child these questions:

Why wasn't God pleased with Cain's offering?

Is God pleased with our offerings today if we really don't want to give them?

---



Cain got very mad at Abel because God was pleased with Abel's offering but not his. One day when they were in the field Cain hit Abel so hard that he killed him.

---

Parents: Explain what jealousy is and what it can make you do sometimes. Which commandment did Cain break here? What should Cain have done instead of hitting his brother when he was angry with him?

---



When God asked Cain where Abel was, Cain lied. He told God he didn't know. God knew what Cain had done, so He put a mark on Cain and sent him and his wife away from home. Now Cain was lonely. He must have felt much the same way his mother and father did when God sent them out of the Garden of Eden.

---

Parents: Ask your child these questions:  
Which commandment did Cain break when he lied?  
Why did God send Cain away?  
Have you ever felt all alone?

---



Cain's murder of Abel was the beginning of all the crime that you see in the world today. This is how wars begin. (Find pictures of crime and paste them here.)

---

---

## CROSSWORD PUZZLE

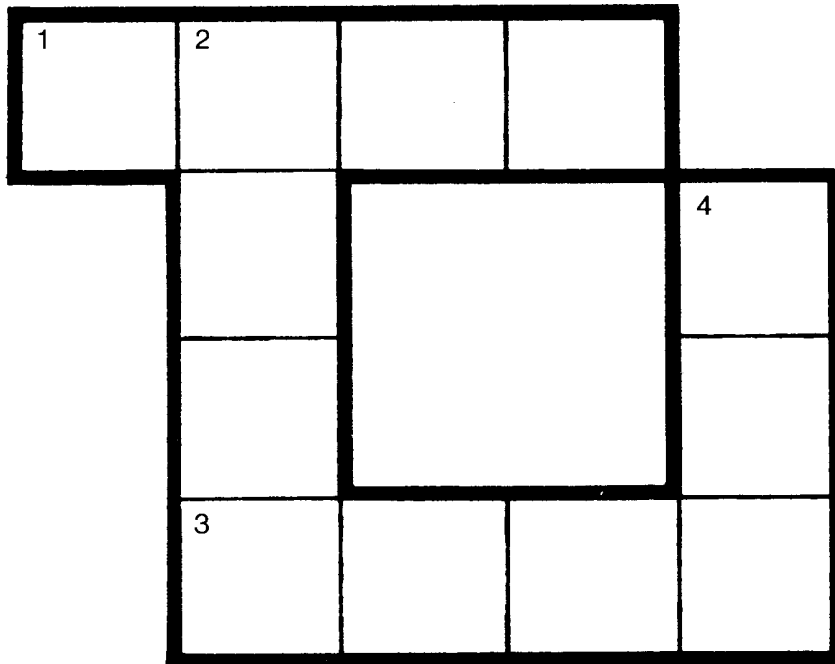

### Across

- \_\_\_\_\_ was the first man to kill someone.
3. Cain \_\_\_\_\_ to God when he said he didn't know where Abel was.

### Down

2. \_\_\_\_\_ was Cain's brother.
4. Abel's offering pleased \_\_\_\_\_.

---

Answers:      GOD    ABEL    LIED    CAIN

---

---

## WORD SEARCH

Find the words in the puzzle below and circle them.

S A O N B D O H G T L C D A O X  
M C E F T S F Z I U N **S** E T B A  
T F K E G I F H W A G **E** F L N T  
L G T C A B E G O D L L K S C J  
R K S F A I R Q X A Y B L M Y X  
V I P B M I I R V M C A D E C T  
C L E X L J N Y J K B T E V N W  
K L O V E P G M N T L E X B D M  
T C Z M E R L T M S A G B L C D  
S Y L B L T H K J E S E T F H I  
A B O L A M B E D F G **V** K G L C  
X Q P M T X E T L B A N C J V W

CAIN

GOD

ABEL

LAMB

VEGETABLES

LOVE

KILL



OFFERING

EVE

ADAM

---

## BIBLE TIC-TAC-TOE

Kill	Cain	Obedient
		Shepherd
Abel		Murder

To find out who wins the Tic-Tac-Toe game, Cain or Abel, give Cain O's for all things having to do with Cain and X's for all things having to do with Abel.

winner: \_\_\_\_\_

---

**BIBLE MEMORY**

Books of the  
New Testament

- |                         |                     |               |                |
|-------------------------|---------------------|---------------|----------------|
| 1. Matthew              | 8. 2 Corinthians    | 15. 1 Timothy | 22. 2 Peter    |
| 2. Mark                 | 9. Galatians        | 16. 2 Timothy | 23. 1 John     |
| 3. Luke                 | 10. Ephesians       | 17. Titus     | 24. 2 John     |
| 4. John                 | 11. Philippians     | 18. Philemon  | 25. 3 John     |
| 5. Acts of the Apostles | 12. Colossians      | 19. Hebrews   | 26. Jude       |
| 6. Romans               | 13. 1 Thessalonians | 20. James     | 27. Revelation |
| 7. 1 Corinthians        | 14. 2 Thessalonians | 21. 1 Peter   |                |
- 

## A SHORT QUIZ

1. Who killed Abel?

\_\_\_\_\_

2. Who was the farmer?

\_\_\_\_\_

3. Who was the keeper of sheep?

\_\_\_\_\_

4. Whose offering pleased God?

\_\_\_\_\_

1. Cain    2. Cain    3. Abel    4. Abel

---

# YOUTH

LEVEL 2

---

# BIBLE

---

# LESSONS

LESSON 4

---



Noah and the Flood

---

# NOAH AND THE FLOOD

---

God was very unhappy when He saw all the crime, war and pain on the earth. There was only one man who was obeying God. That man was Noah. God told Noah He was going to send a flood that would destroy every man, bird and animal on the earth. He also told Noah that He would save him and his wife and his sons and their wives. He said he would do this because Noah obeyed God. And so God told Noah to build a big ark, or ship, to save them from the Flood.

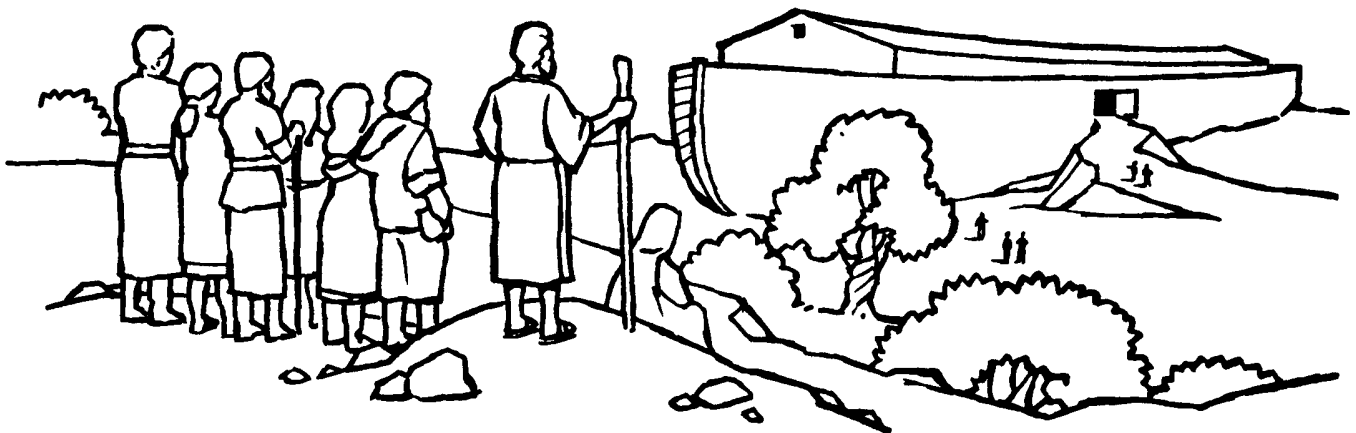

---

Parents: Have your child color the picture. Also ask your child what crime is and what causes crime. Explain that people should practice the way of "give" instead of "get." Your child can give by sharing toys and helping others.

---



Many trees  
had to be cut  
for wood to  
build the ark.

A frame  
for the ark  
had to be  
made.

The ark  
had to be sealed  
with tar.

For 120 years Noah worked on the ark. For 120 years Noah told the people that God was going to send a flood because they did not obey Him. The people did not believe him.



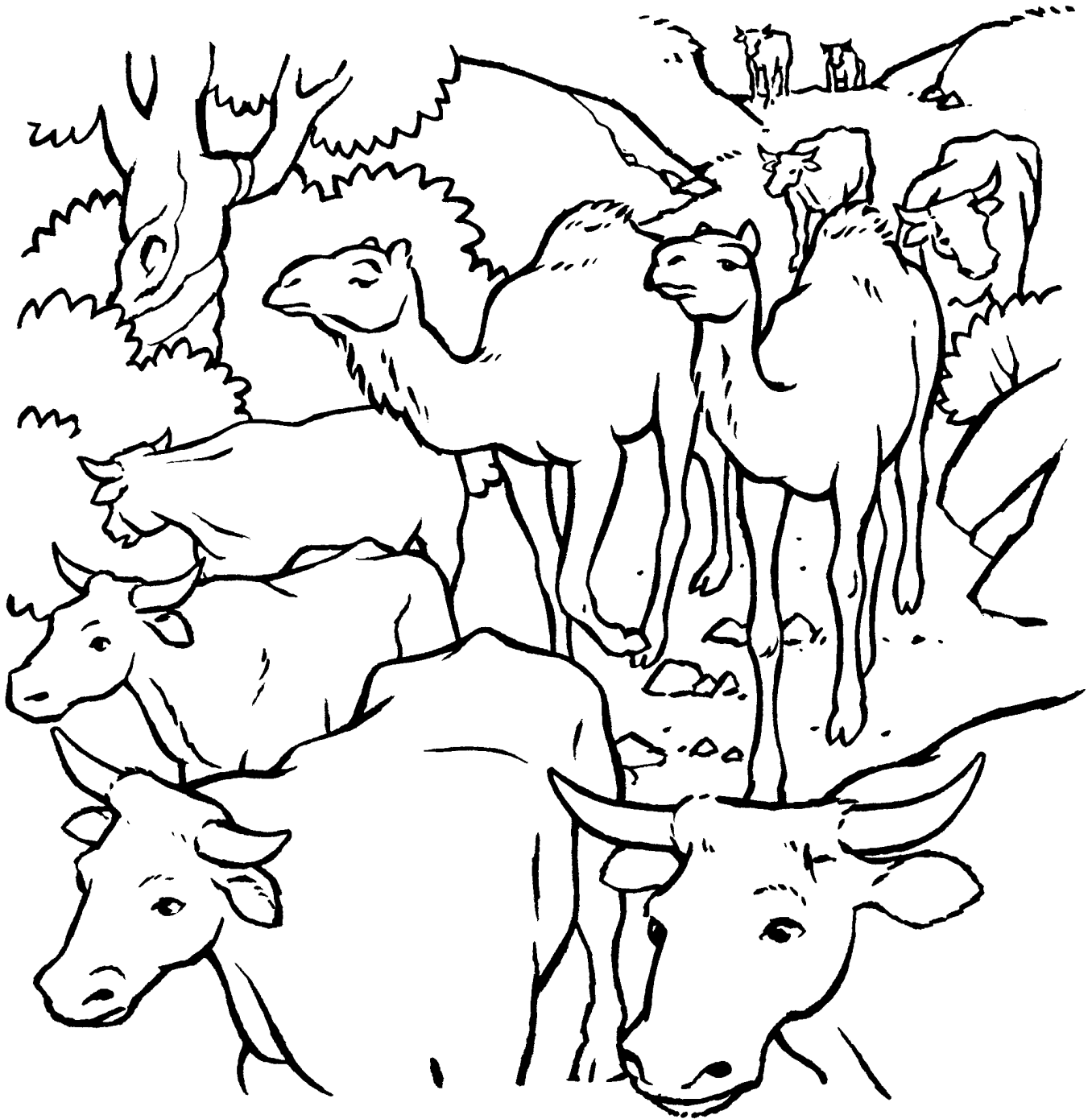

Then one day God made the animals and birds to come to the ark. One pair of each unclean animal came and seven pairs of each clean animal came.

---

Parents: Explain briefly the meaning of "clean" and "unclean" animals (that it doesn't mean washed or unwashed).

---

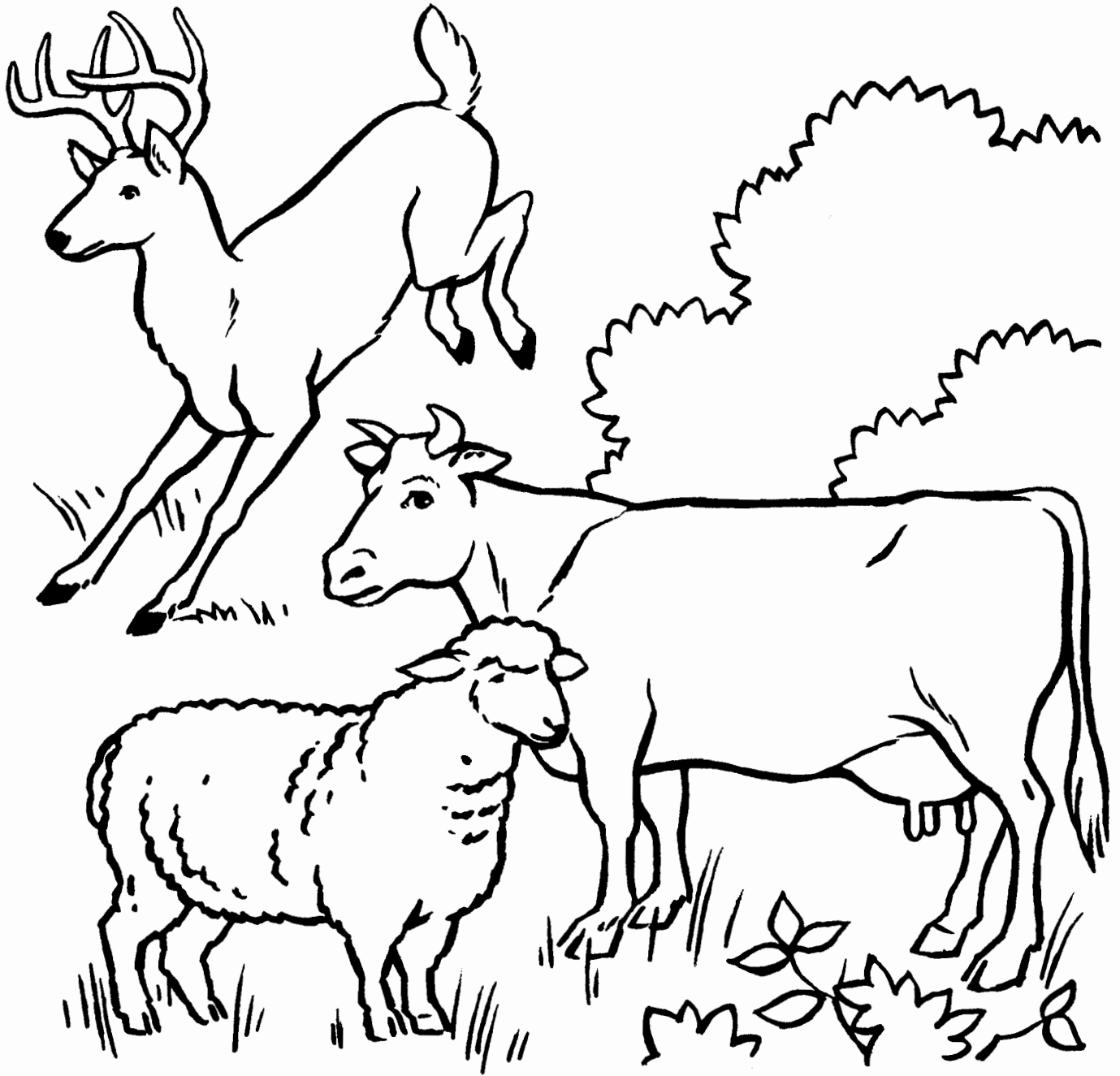

God told Noah to take seven pairs of clean animals on the ark. God did this so Noah and his family would have food to eat. There would still be some of these animals left to start having babies after the Flood. These are some of the animals God says we may eat.

---

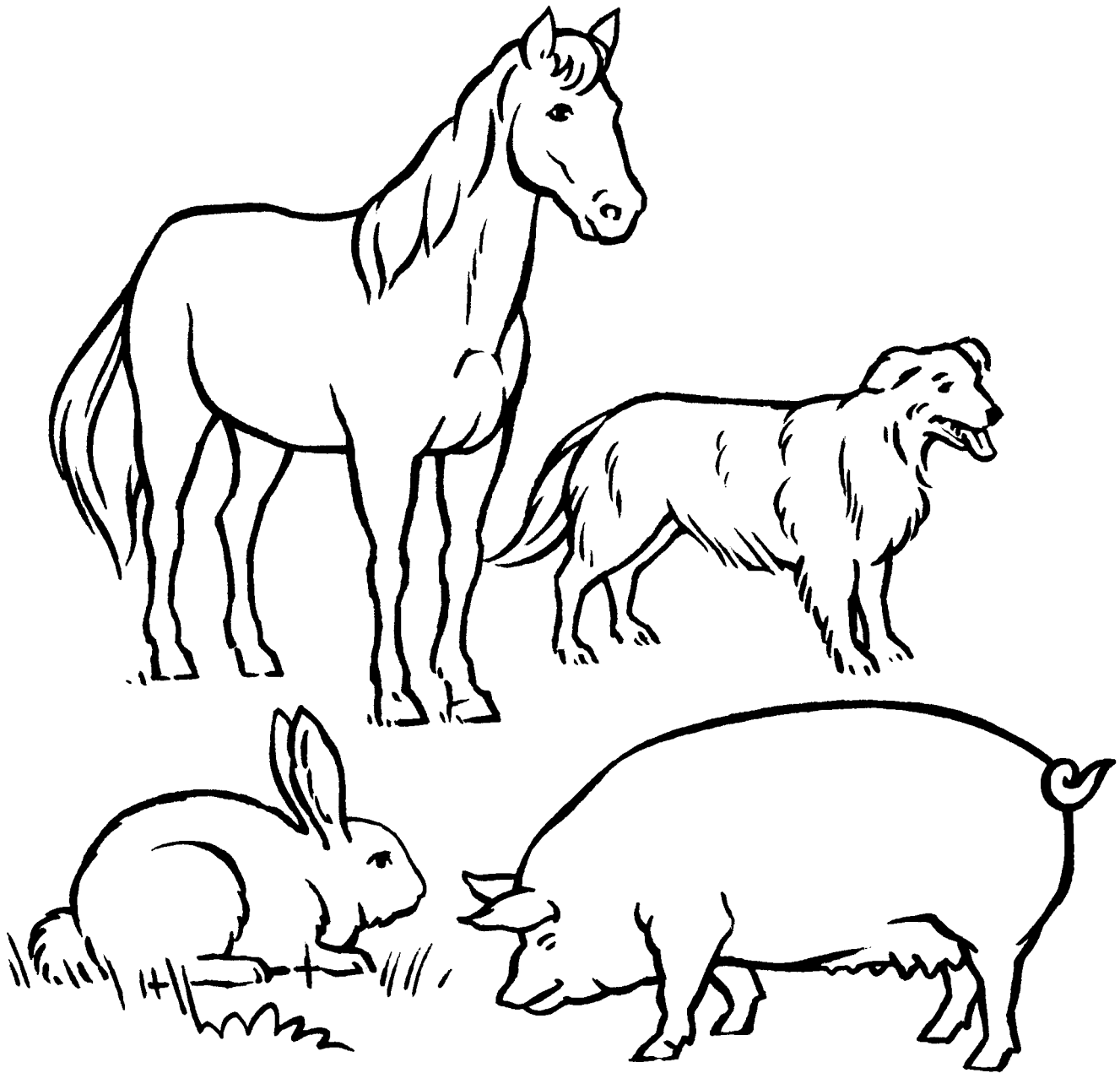

God told Noah to take only one pair of the unclean animals into the ark. These needed to be taken so that they could have babies after the Flood.

---

Parents: Explain to your child that if God had not saved some of each kind of bird and animal to repopulate the earth there would be no birds or animals today.

---

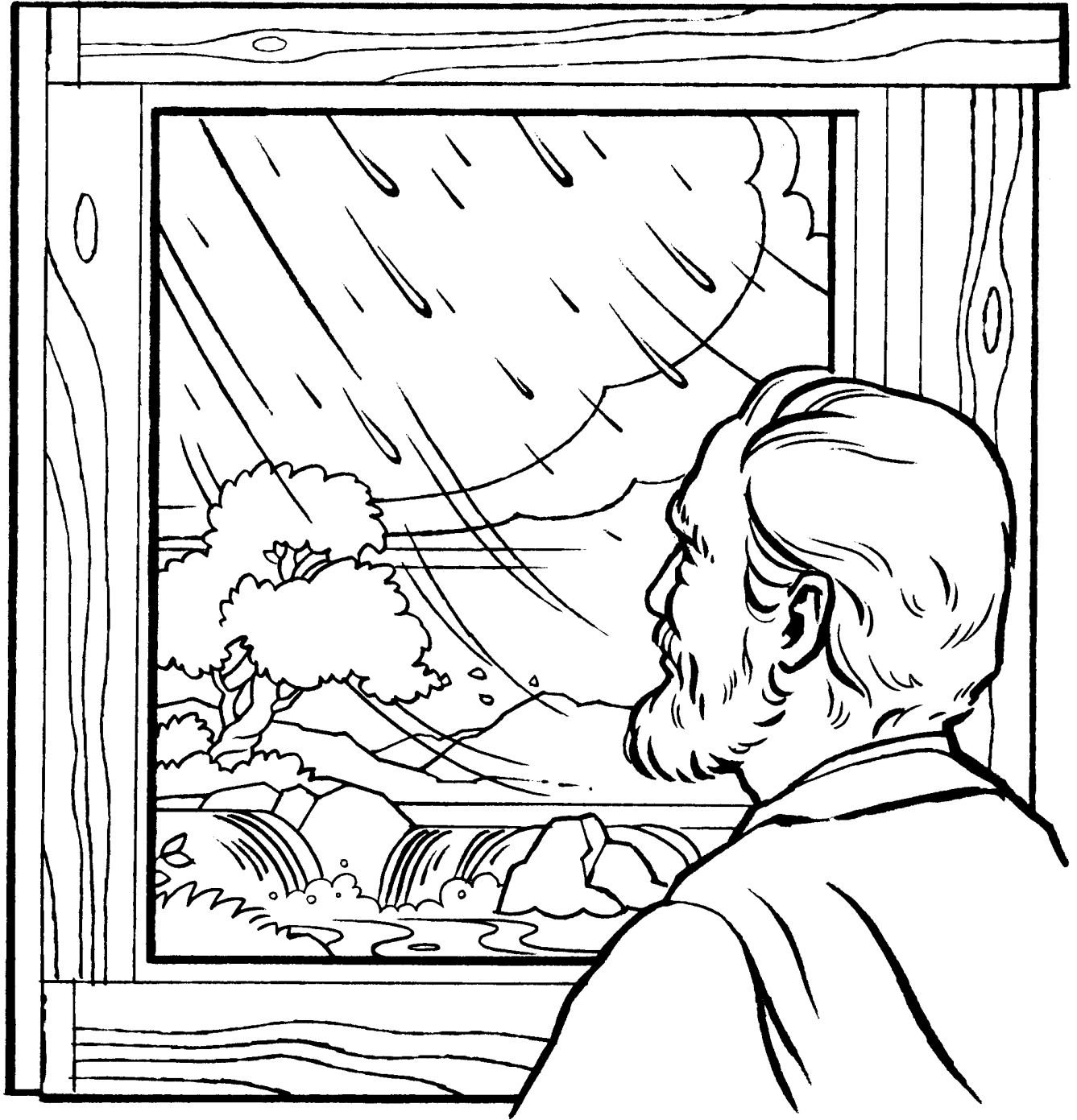

The people laughed at Noah as he and his family entered the ark. God shut them and the animals inside. One week later the sky grew dark and rain began to fall. Soon the ark began to float.

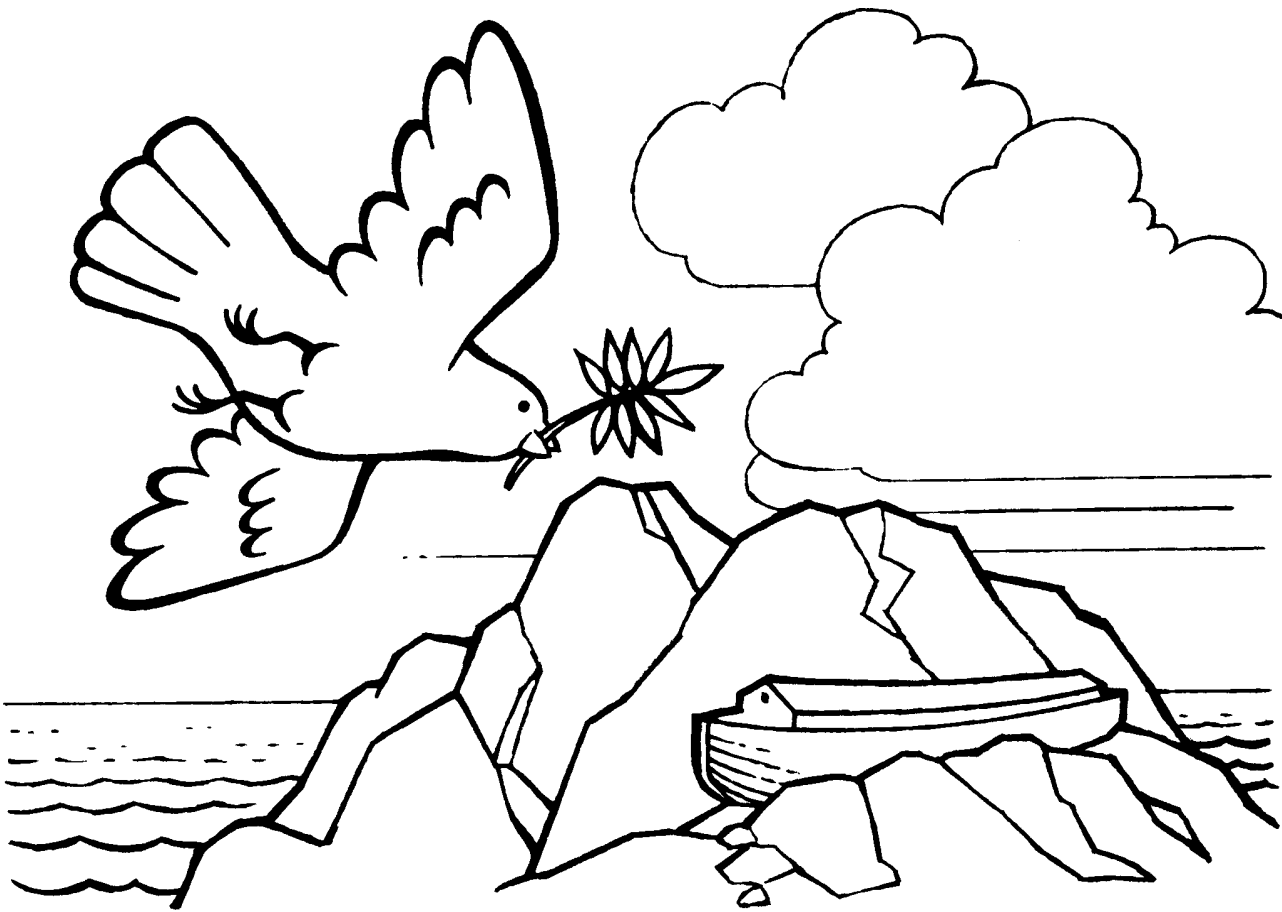

God made it rain 40 days and 40 nights. The ark floated on the water for 150 days. Then God sent a strong wind to make the water go down and the ark came to rest on a mountain. After being on the mountain top for forty more days, Noah sent out a dove. Soon the dove came back. After a week Noah sent the dove out again. This time it came back with a leaf in its beak. The next time Noah sent the dove out, it did not come back. This told Noah it was time to leave the ark because there was dry land.

---

Parents: Explain to your child in simple terms that the wind caused some of the water to evaporate with other water going back into the ground but some remained as lakes. Also mention that scientists admit there is enough water in the air, on land, and underground to cover the entire earth when the mountains were a bit lower.

---

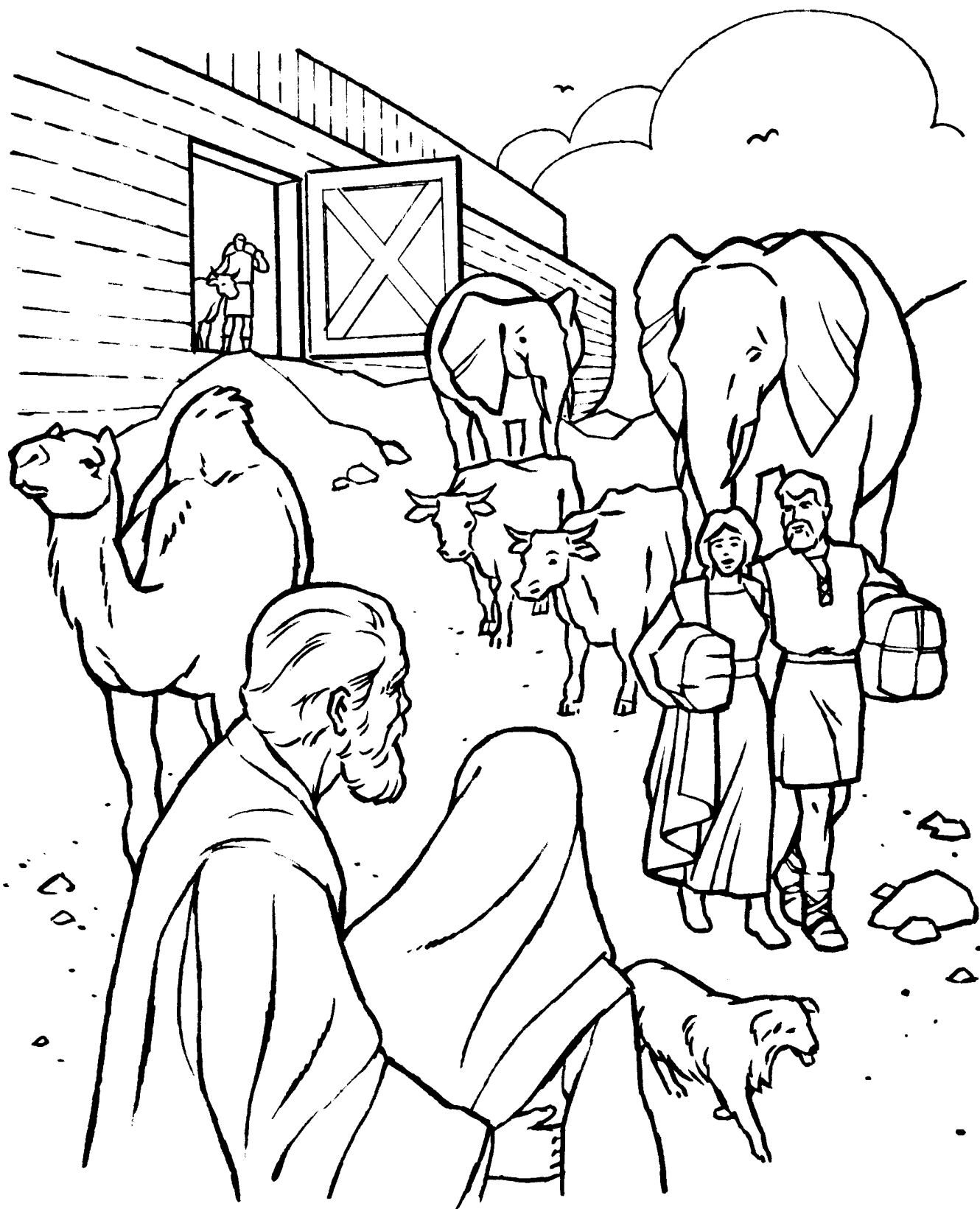

Noah and his family and all the birds and animals left the ark to start a new life on the earth.

---

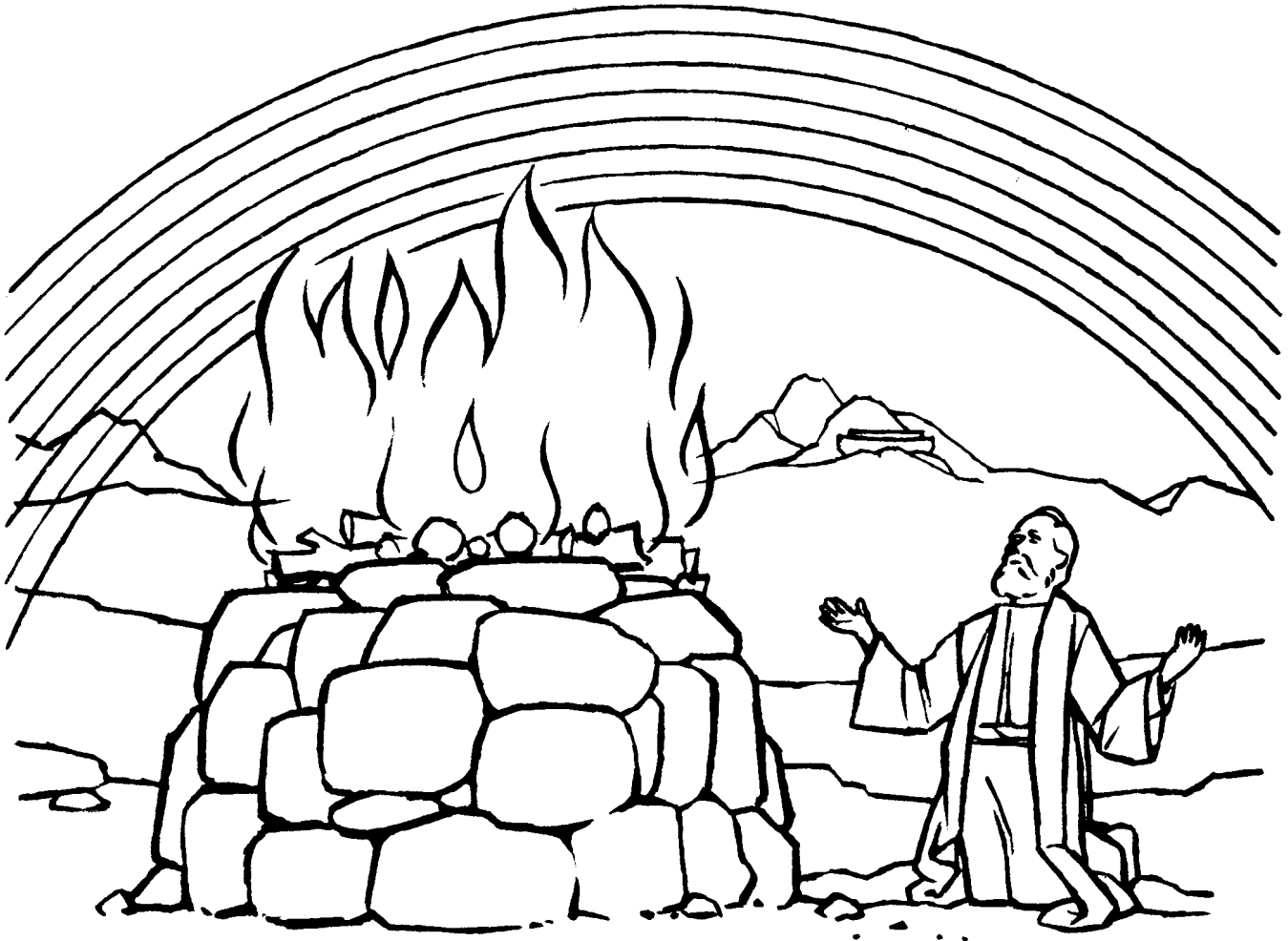

Noah was very glad to be safe and back on the land. He made an altar and gave a thank offering to God. God promised Noah that He would never destroy the earth again with a flood. As a reminder of this promise God made a rainbow. Sometimes we can see a rainbow today when it rains while the sun is shining. Do you know the colors of the rainbow?

---

Parents: Explain to your child that all rainbows are made up of the same colors in the same order. An easy way for them to remember the colors and their order from the largest arc to the smallest arc is to spell out the name ROY G. BIV. The letters of this name are the first letters of the colors red, orange, yellow, green, blue, indigo and violet.

---

## Do You Remember?

1. How many years did Noah work on the ark?

\_\_\_\_\_.

2. How many people were saved from drowning during the Flood?

\_\_\_\_\_.

3. What sign did God give to remind us of His promise not to destroy the earth again by a flood?

A \_\_\_\_\_.

## Unscramble the Letters to find words from the story

1. kra \_\_\_\_\_
2. hNao \_\_\_\_\_
3. oldof \_\_\_\_\_
4. nraibwo \_\_\_\_\_
5. vdoe \_\_\_\_\_

dove      rainbow      flood      Noah      ark



**BIBLE MEMORY**

God's Festivals

Passover  
 Days of Unleavened Bread  
 Pentecost  
 Feast of Trumpets

Day of Atonement  
 Feast of Tabernacles  
 Last Great Day

**NOAH AND THE FLOOD CROSSWORD**

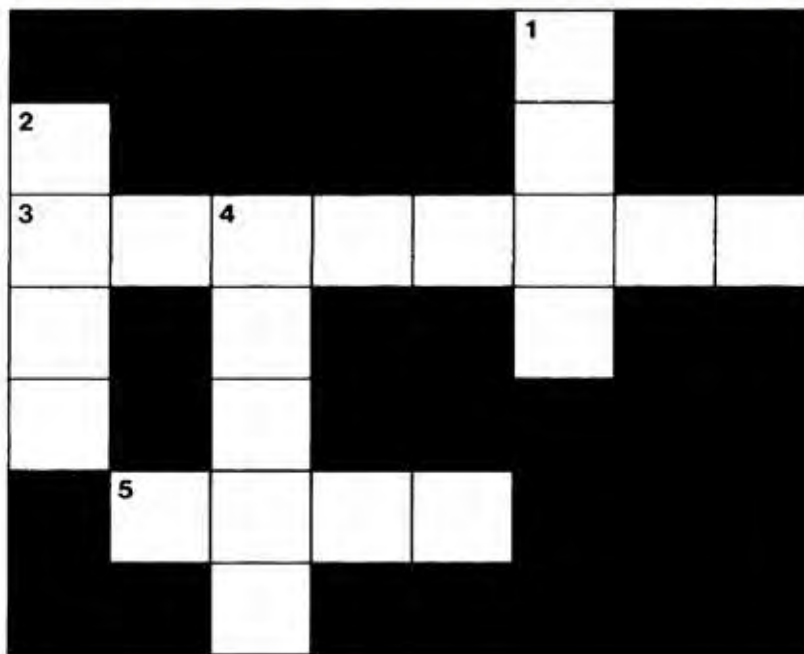

**Across**

- 3. What Noah gave to God after he left the ark.
- 5. \_\_\_\_\_ and his sons built the ark.

**Down**

- 1. God made it \_\_\_\_\_ 40 days and 40 nights.
- 2. A bird Noah sent out of the ark.
- 4. God sent a \_\_\_\_\_ to destroy all life upon the earth.

**ANSWERS:**  
 Across 3. Offering 5. Noah  
 Down 1. Rain 2. Dove 4. Flood

---

# YOUTH

---

LEVEL 2

# BIBLE

---

# LESSONS

---

LESSON 5

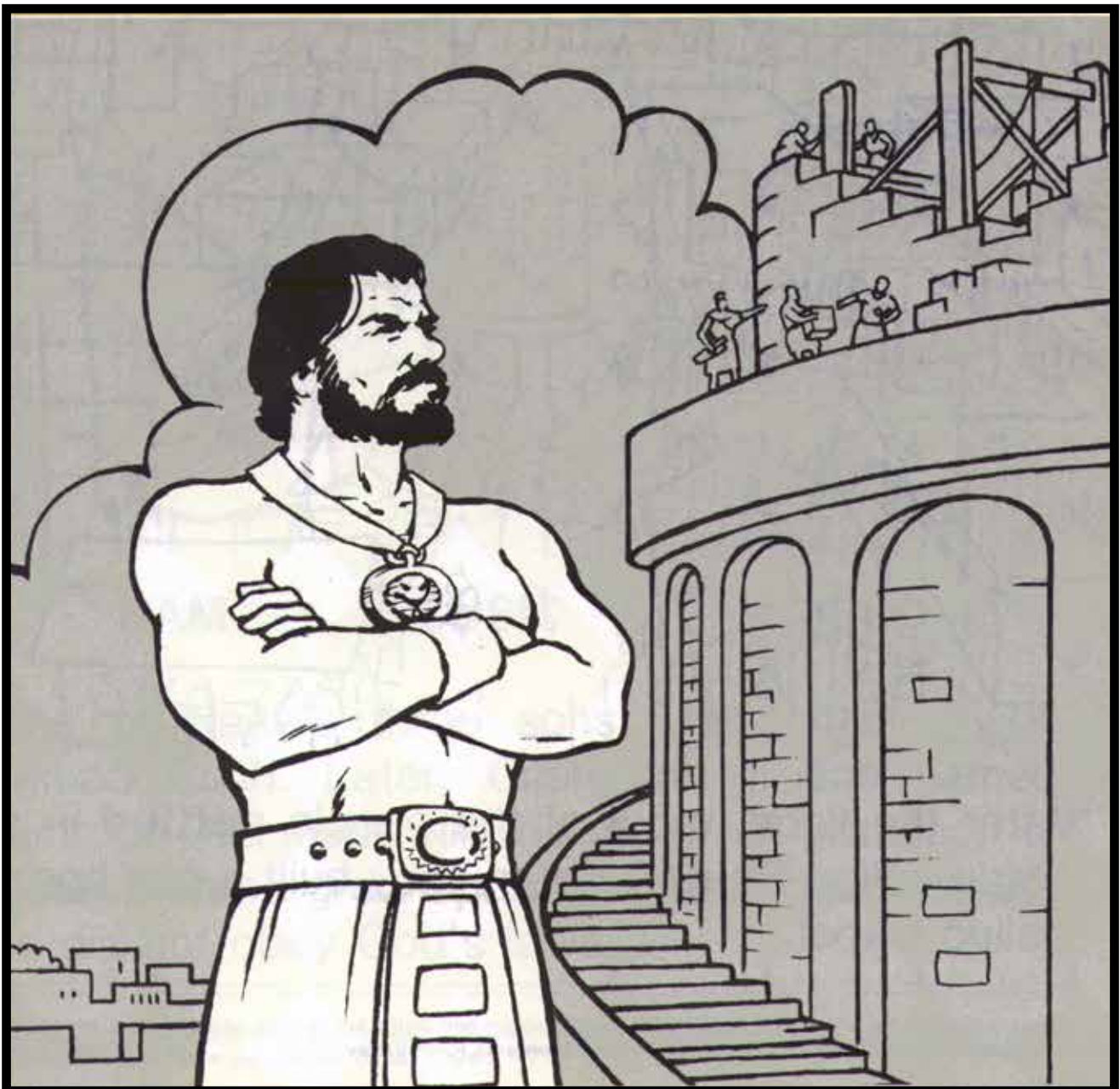

Nimrod and the Tower of Babel

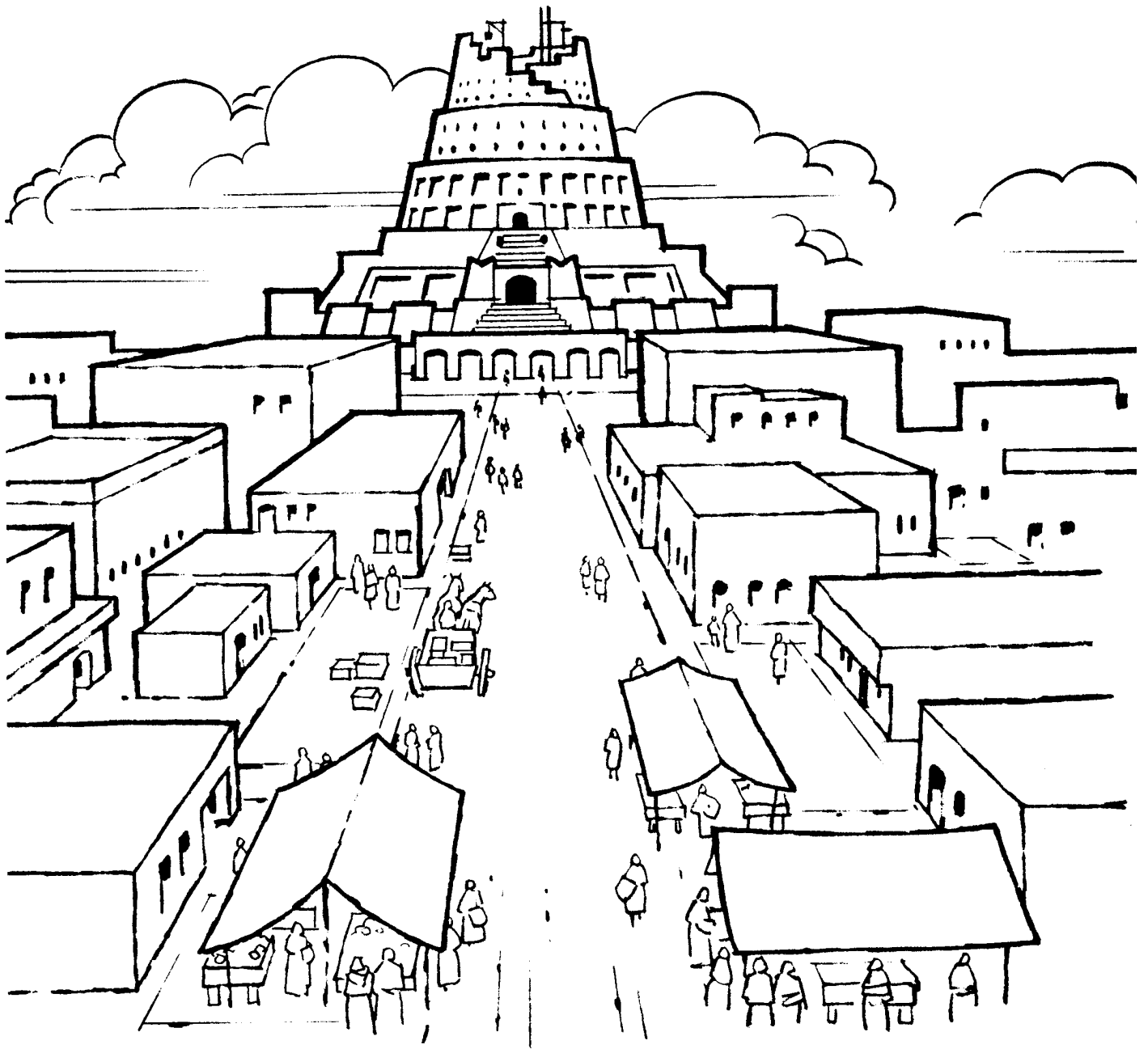

After the flood, most of the people **settled** in a place called **Shinar**. Later, they built a city here, called **Babel**.

---

Parents: Explain the meaning of the **boldface** words above and on the succeeding pages. Shinar was a very fertile area located in Mesopotamia in the Tigris-Euphrates River Valley.

---

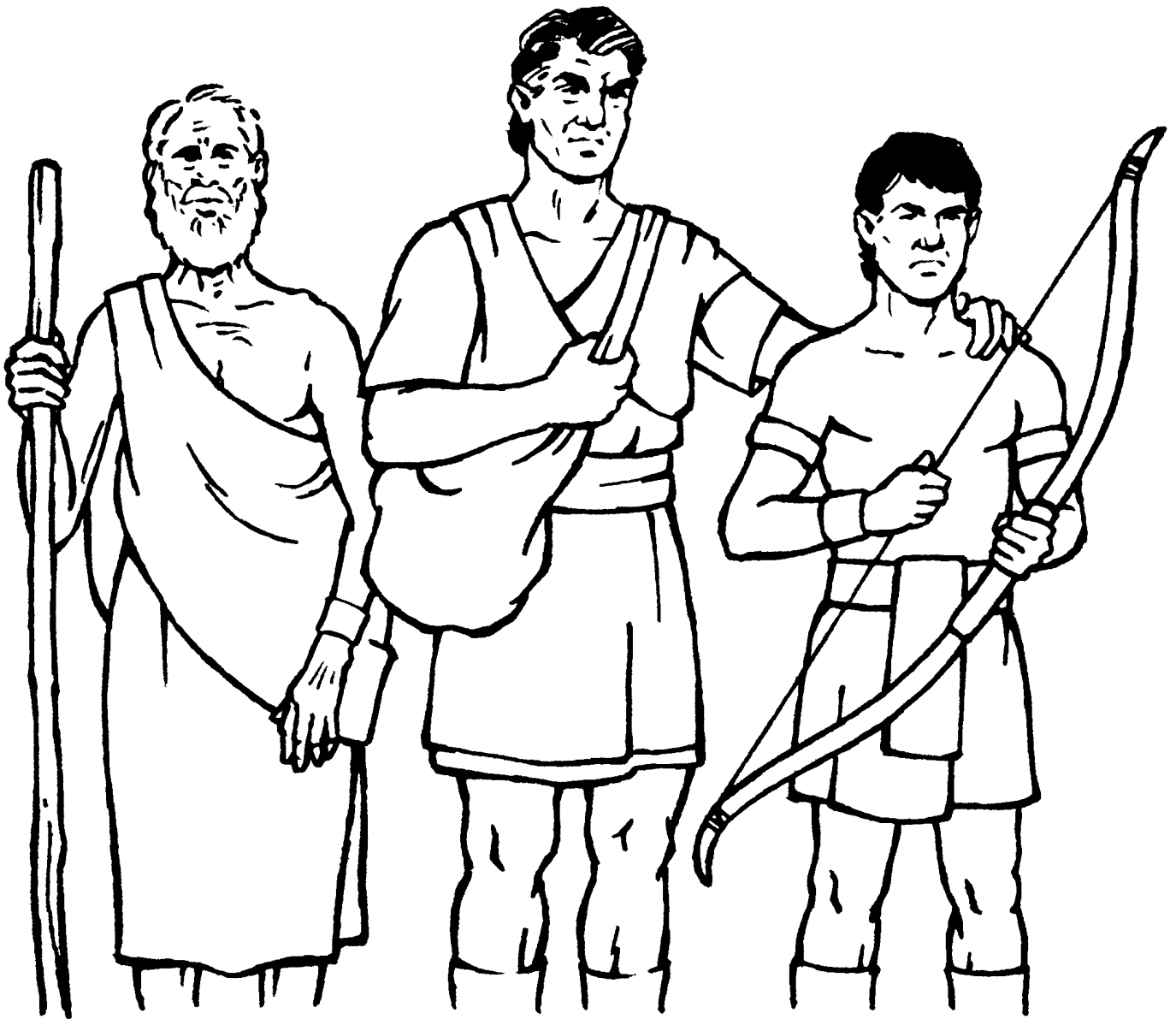

**HAM**

**CUSH**

**NIMROD**

One of Noah's three sons, Ham, had a son named Cush. Later, Cush had a son named Nimrod. This made Nimrod the great grandson of Noah. Nimrod grew up to be a strong hunter, but he did not obey God's laws.

---

Parents: In simple terms, help your child to understand the approximate period of time that must have elapsed between these generations (read Genesis 10).

---

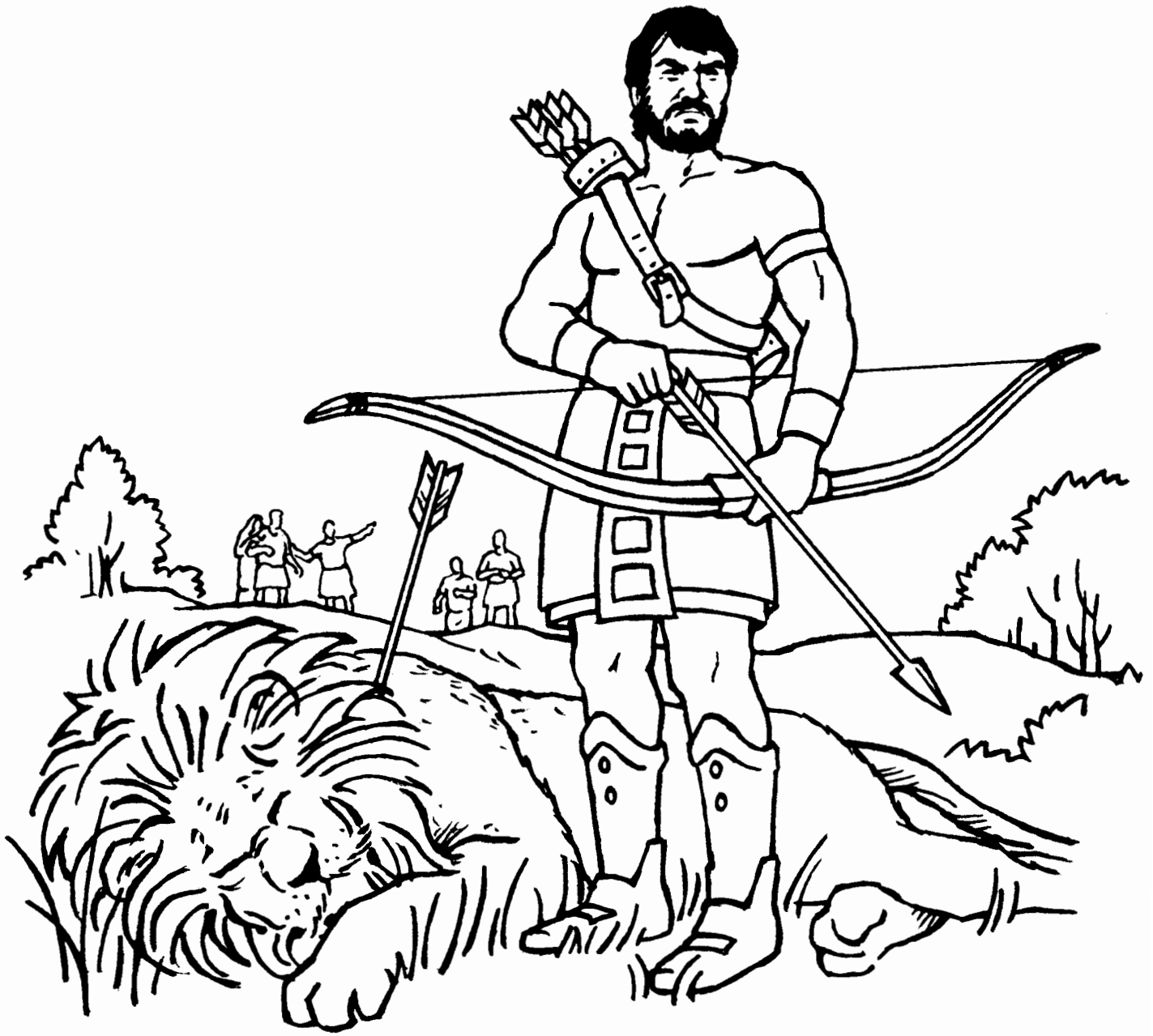

The people who lived in the city of Babel began to look to Nimrod as their **hero**. One **reason** they did is because he **protected** them from wild animals that came near the city.

---

Parents: Explain that cities then were quite different and were out in the open places where wild animals lived.

---

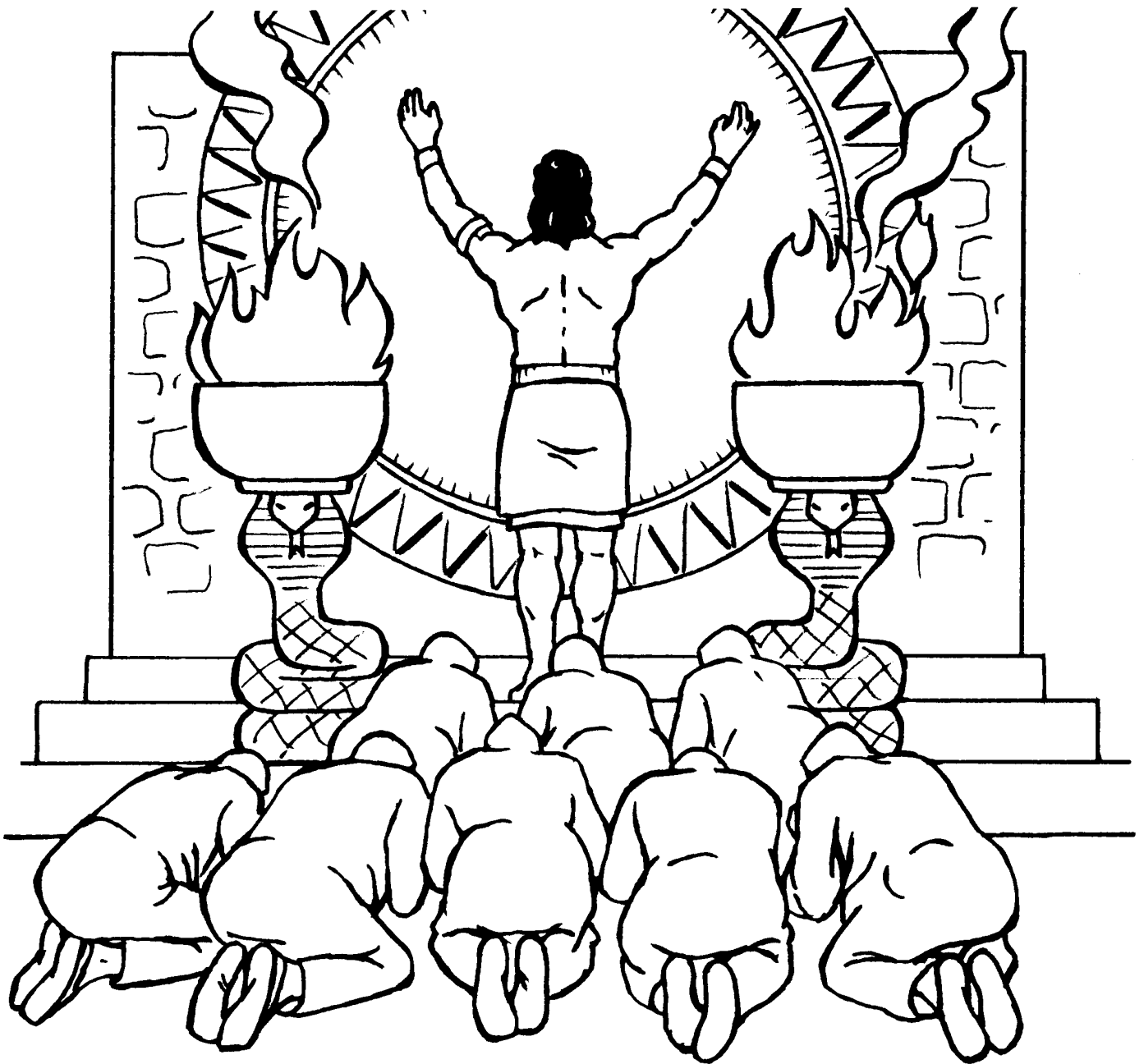

Nimrod wanted the people to look to him as their **ruler**, instead of God. He taught them to **worship** things such as the sun and snakes, instead of God. The people liked this because they wanted to worship things they could see and touch.

---

Parents: Explain that the people were actually worshipping Satan, who is behind all idol worship. You may need to briefly explain about Lucifer who rebelled against the government of God and has been influencing mankind to disobey God for the past 6000 years.

---

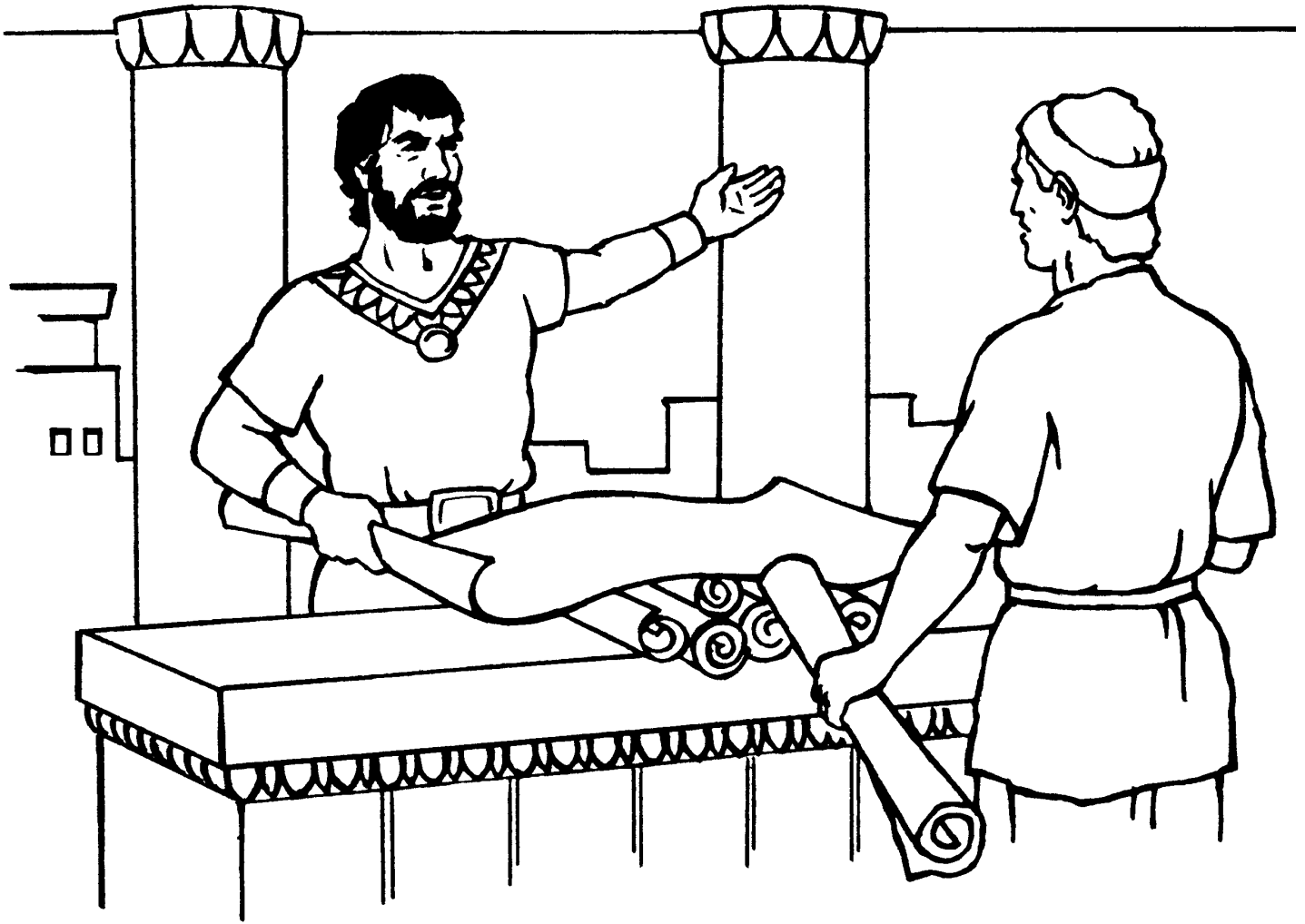

Nimrod knew he had to get the people working **together** on a **project** so he could keep **control** over them. So, he put them all to work **building** a tower. He wanted this tower to reach to **heaven**. At this time all of the people spoke the same **language**. This made it easy for Nimrod to give orders because they all **understood** him.

---

Parents: Discuss how many heavens there are and what is in each of them.

---

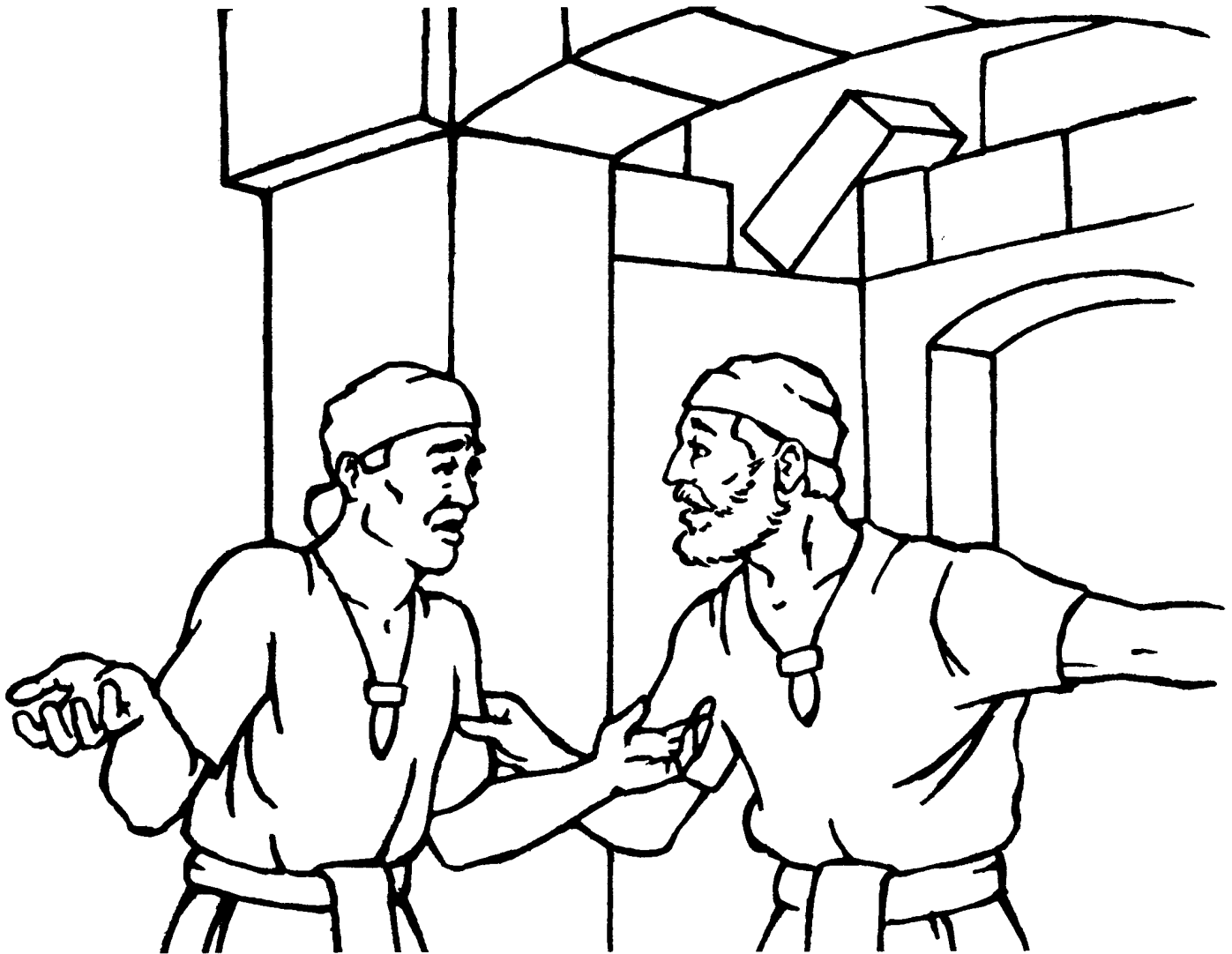

God saw what Nimrod and the people were doing. If He allowed them to **continue** with this project, the people would become as evil as they were before the Flood. So God caused many of the people to start talking in different languages. The work on the tower stopped because of the **confusion** created when people could no longer understand each other. This is what the word “babel” means—confusion.

---

Parents: Explain that this would be just as confusing as trying to learn to read or do math from a teacher who speaks in a different language. One simply couldn't do his assignments!

---





The people began to group together with others who spoke the same language as they did, and move away from the city to other parts of the world. Without people to work on the tower, it was never finished.

---

Parents: Explain simply that this is how we came to have all the different languages around the world. See the language exercise on page 11 and be sure to help your child with it.

---

---

## DO YOU REMEMBER?

1. \_\_\_\_\_ became a hero to the people.
2. The people began to build a \_\_\_\_\_.
3. \_\_\_\_\_ was Nimrod's father.
4. \_\_\_\_\_ means confusion.

NIMROD   TOWER   CUSH   BABEL

---

## CROSSWORD PUZZLE

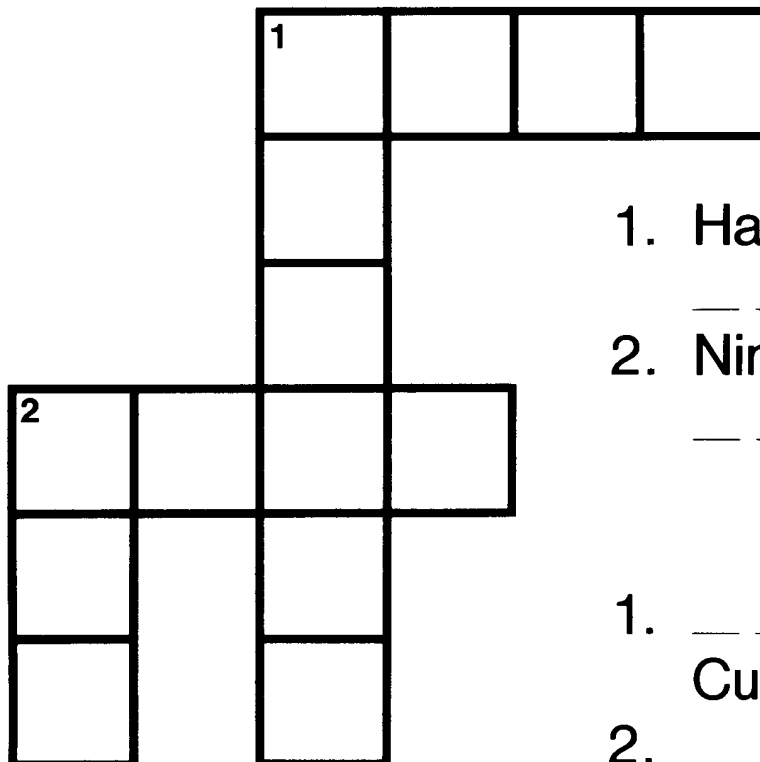

### ACROSS

1. Ham's father was \_\_\_\_\_.
2. Nimrod became a \_\_\_\_\_ to the people.

### DOWN

1. \_\_\_\_\_ was Cush's son.
  2. \_\_\_\_\_ was Cush's father.
-

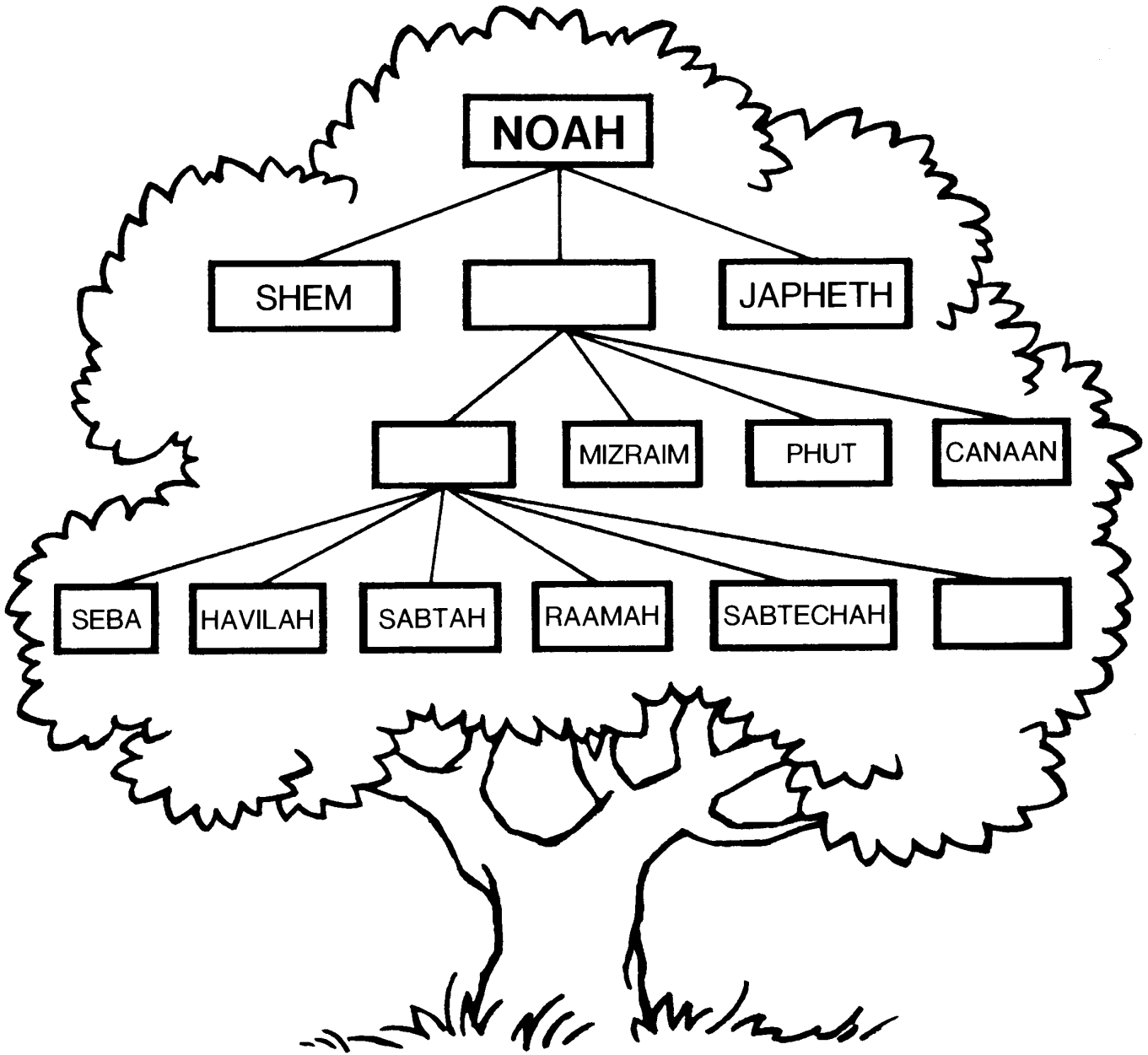

This is a part of Noah's family tree. Fill in the empty boxes to see how Nimrod is related to Noah.

---

Parents: Perhaps you could help your child make a simple family tree of his own so he could further understand his own genealogy.

---

## DIFFERENT LANGUAGES

Language	Nations where language is spoken
1. _____	_____
2. _____	_____
3. _____	_____
4. _____	_____
5. _____	_____
6. _____	_____
7. _____	_____
8. _____	_____
9. _____	_____
10. _____	_____

Think of as many languages as you can. Write down the names of the languages on the lines in the left-hand column. On the line next to each language, list some of the nations where that language is spoken.

---

**BIBLE MEMORY**

God's Festivals

Passover  
 Days of Unleavened Bread  
 Pentecost  
 Feast of Trumpets

Day of Atonement  
 Feast of Tabernacles  
 Last Great Day

**CONNECT  
 THE DOTS**

See what the  
 people of Babel  
 started to build,  
 but never  
 finished.

19 ●

● 18

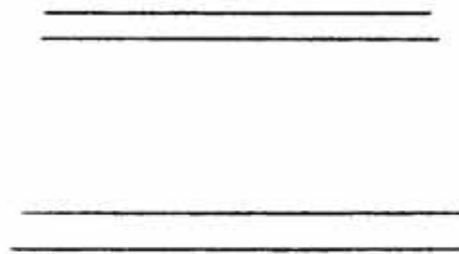

21 ● ● 20

● ● 16  
 17

23 ● ● 22 ● 6 ●

7 ● 15 ● ● 14 ●

4 ● ● 24

5 ● ● 1

9 ● ● 8

13 ● ● 12 ●

● 3

● 2

● 10

● 11

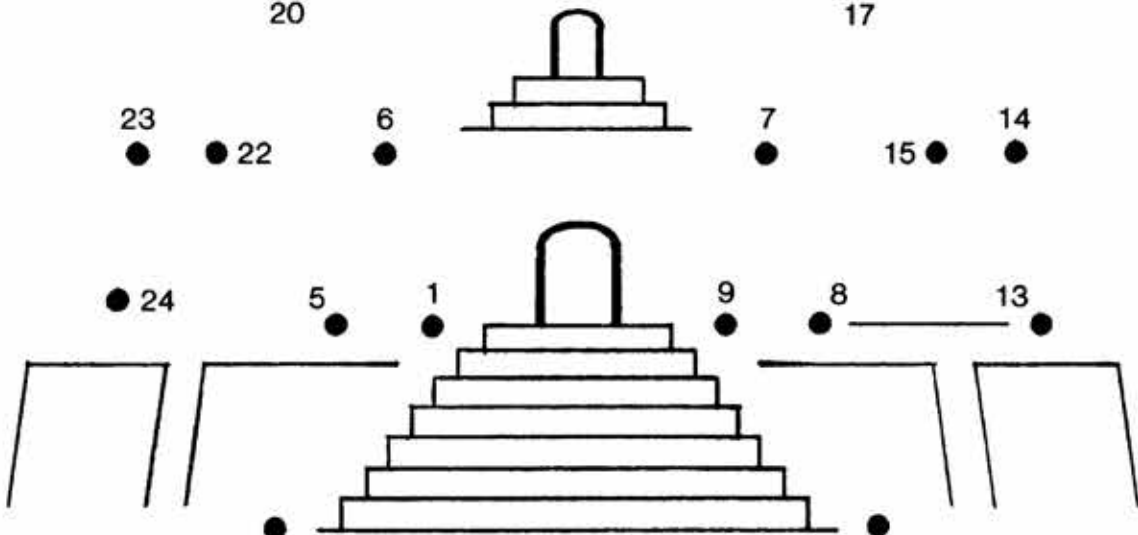

---

# YOUTH

LEVEL **2**

---

# BIBLE

---

# LESSONS

LESSON **6**

---

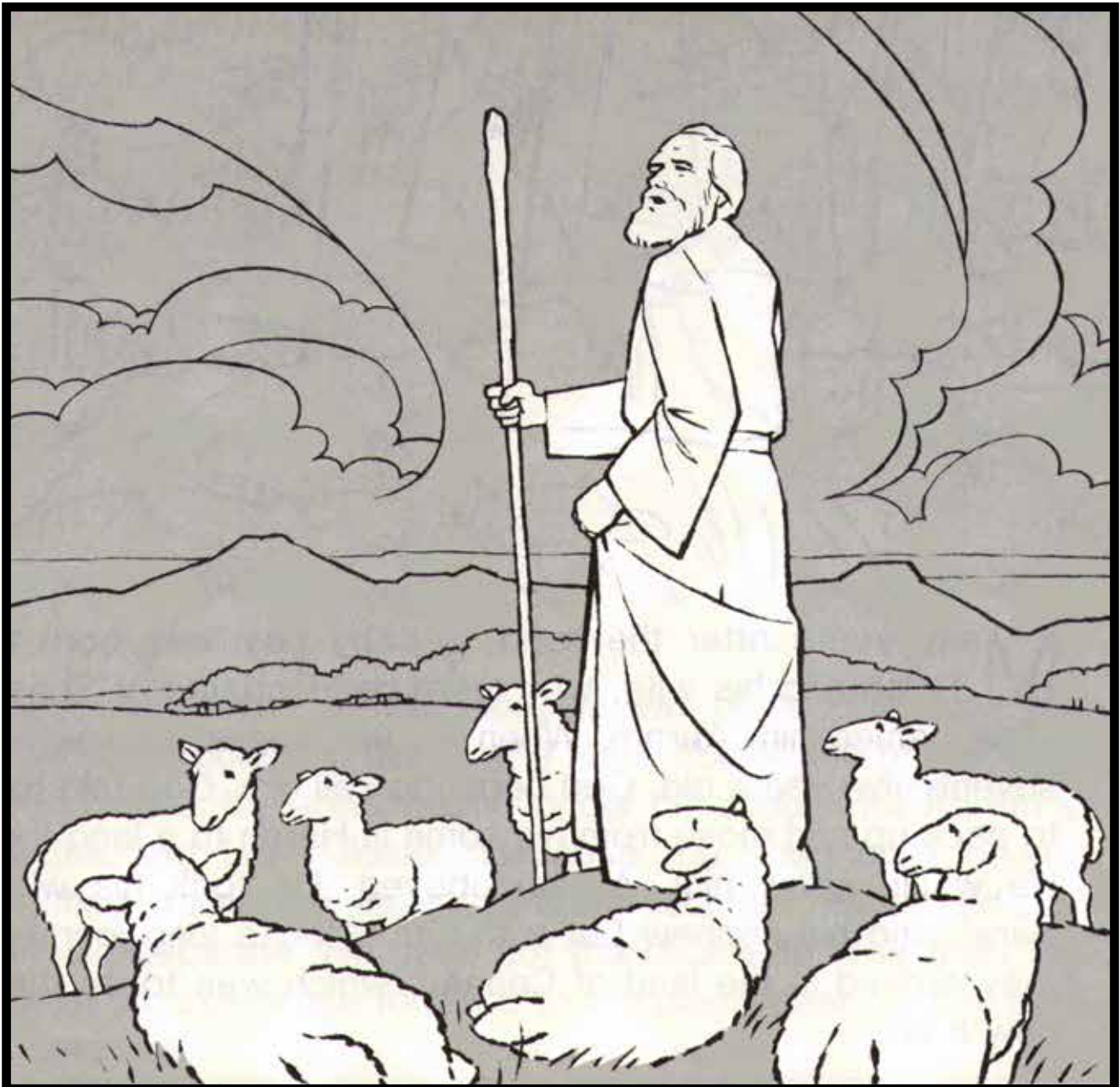

Abraham Obeys God



**M**any years after the flood, a baby boy was born to Terah and his wife, who were descendants of Shem. They named him Abram. When Abram was a grown man seventy-five years old, God began to call him. God told him to pack up and move from his home in Haran to a land that He would show him. Abram obeyed. He took his wife, Sarai, and his nephew Lot with him. After a long journey, they arrived in the land of Canaan, which was to be their new home.



Because Abram obeyed God, he was blessed greatly. He had much gold and silver, and many flocks and herds. In a short while, the area was no longer big enough for Abram's flocks and Lot's flocks. Because the shepherds began fighting among themselves, Abram decided that he and Lot should separate. He gave Lot the choice to stay there or move on. Lot chose to move to the plains near Sodom and Gomorrah.

---



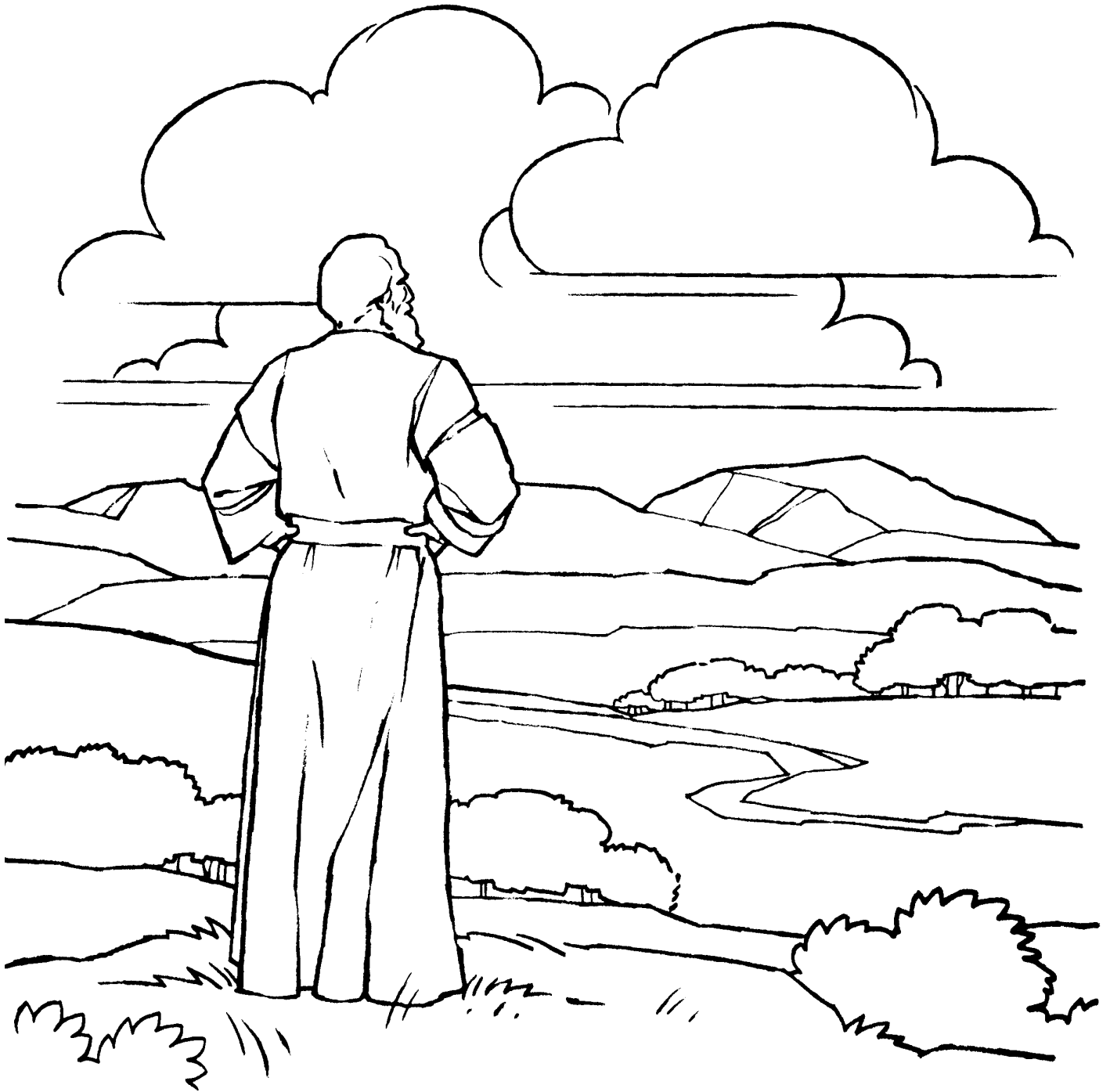

After Lot had gone, God told Abram to look in all directions. All the land he saw God would give to him and his descendants. God promised that he would have so many descendants that they would be as the dust of the earth in number.

---



When Abram was ninety-nine years old, God spoke to him and changed his name to Abraham which means “a father of many nations.” He also changed Sarai’s name to Sarah. God said they would have a son and should name him Isaac.

Some time later, three beings who appeared as men came to visit Abraham. Two were angels; the other was the One who later became Jesus Christ. He told Abraham that Sarah would soon give birth to a son. He also told Abraham that the cities of Sodom and Gomorrah would be destroyed because of the wickedness of the people there.

---



The two angels were sent to Sodom to warn Lot of the coming destruction. When Lot took the angels into his house, the evil men of Sodom wanted them to come out. The men even tried to break down the door to get to them. It was then that the angels struck these men blind. The angels then hurried Lot and his family out of the city. They were warned not to look back as they left.

---

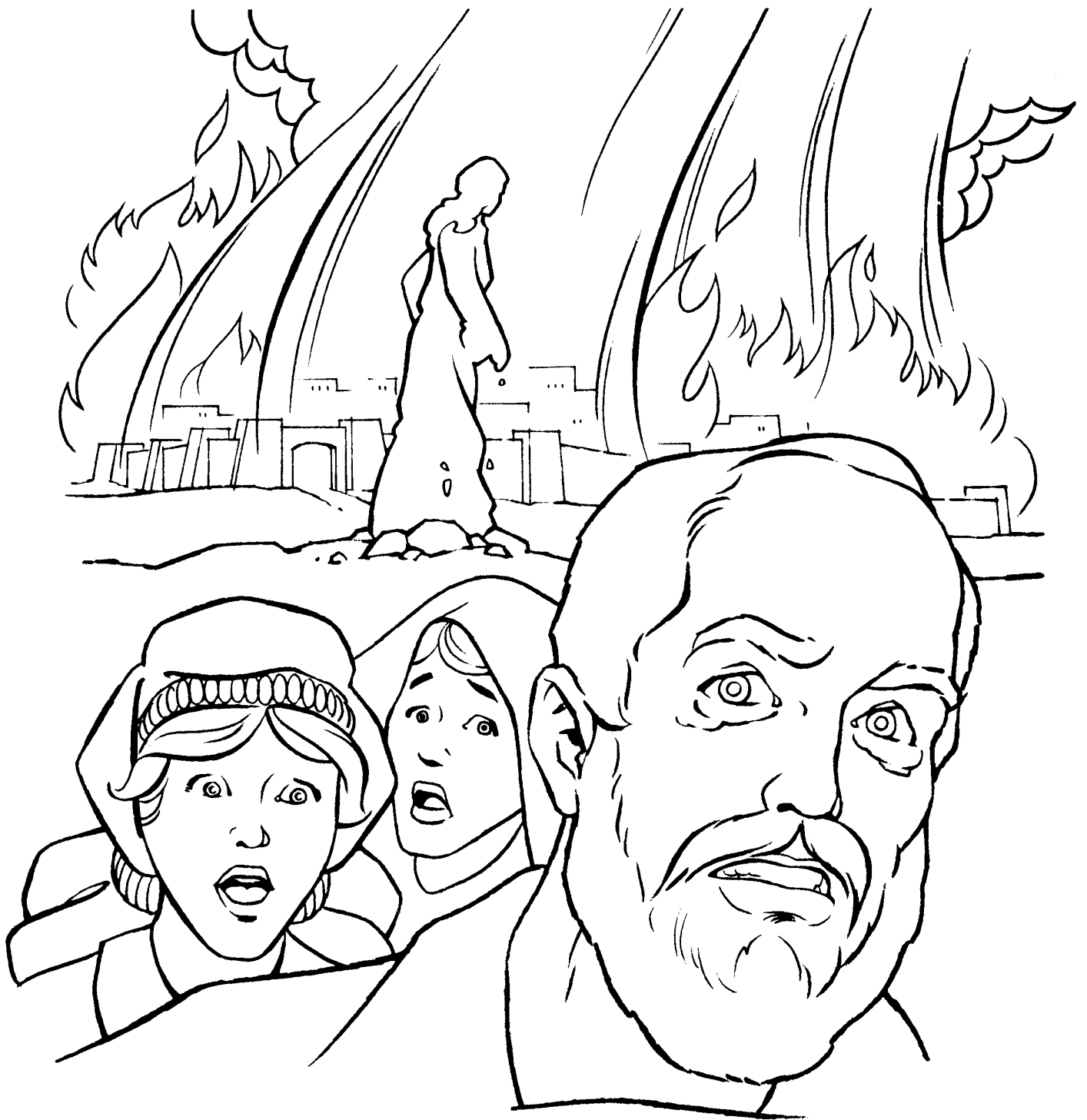

The temptation to look back was too great for Lot's wife. She wanted to take one last look at what had been her home. As punishment for her disobedience, God turned her into a pillar of salt. It is very important that we obey God and do what we are told!

---



It was hard for Abraham and Sarah to believe God would still give them a son because they were both very old by now. But God kept His promise, and when Abraham was one hundred years old and Sarah was ninety years old, Sarah had a son whom they named Isaac.

---

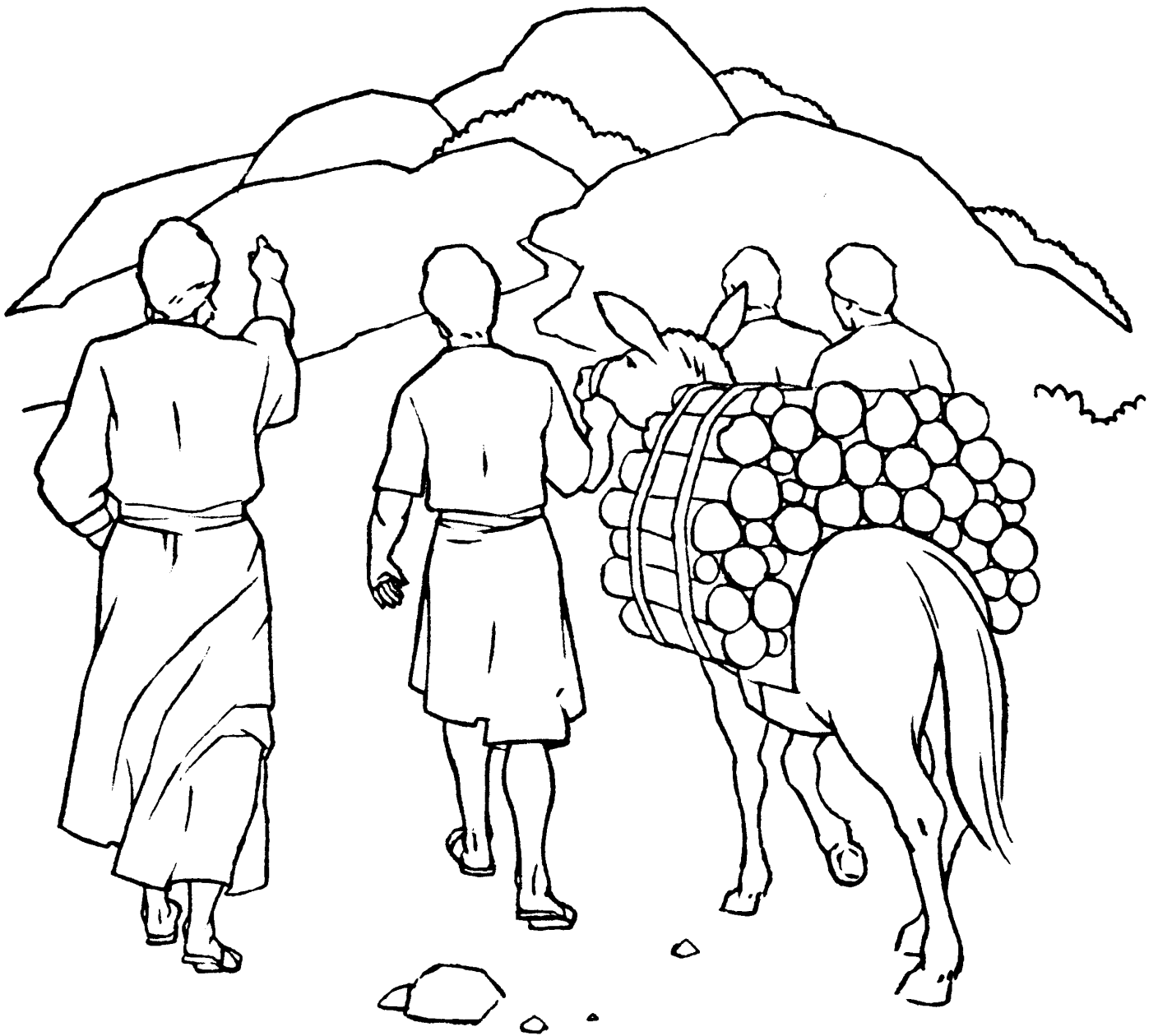

Up to now, Abraham had obeyed God in all he was asked to do. However, God wanted to be sure that Abraham would obey Him by doing whatever He told him to do. So God decided to give Abraham a very difficult test. God told him to offer as a burnt offering his only son, Isaac. Abraham left very early the next morning to do as God had commanded him.

---



As Abraham and Isaac made their way up the mountain, many thoughts must have gone through Abraham's mind. Abraham knew God had promised many children through Isaac. He also knew God could resurrect Isaac. So Abraham trusted God.

As Abraham was about to slay Isaac, God commanded him to STOP! Now God knew Abraham would withhold nothing from Him. Because of this and many other examples of obedience, Abraham became known as the "father of the faithful." Millions of his descendants are still living on the earth today. He died at 175 years of age, having lived a long life of obedience to God.

---

## Do You Remember?

1. What does "Abraham" mean? A \_\_\_\_\_ of many \_\_\_\_\_.
2. When Lot's wife looked back at Sodom and Gomorrah, what did she turn into? A \_\_\_\_\_ of \_\_\_\_\_.
3. When Sarah was 90 years old and Abraham was 100, they had a son and named him \_\_\_\_\_.
4. God tested Abraham by telling him to offer his son as a \_\_\_\_\_.

## Mystery Message

Decode the message below by matching the numbers with the letters, and see how we can follow Abraham's example of obedience.

“

3 8 9 12 4 18 5 14 , 15 2 5 25 25 15 21 18

16 1 18 5 14 20 19 9 14 20 8 5

12 15 18 4 . 6 15 18 , 20 8 9 19 9 19

18 9 7 8 20 (Ephesians 6:1).

<b>A</b>	<b>B</b>	<b>C</b>	<b>D</b>	<b>E</b>	<b>F</b>	<b>G</b>	<b>H</b>	<b>I</b>	<b>J</b>	<b>K</b>	<b>L</b>	<b>M</b>
1	2	3	4	5	6	7	8	9	10	11	12	13
<b>N</b>	<b>O</b>	<b>P</b>	<b>Q</b>	<b>R</b>	<b>S</b>	<b>T</b>	<b>U</b>	<b>V</b>	<b>W</b>	<b>X</b>	<b>Y</b>	<b>Z</b>
14	15	16	17	18	19	20	21	22	23	24	25	26



**BIBLE MEMORY** Matthew 5:16-17  
John 3:16-17

## WORD SEARCH

Find each word from the list below in the word search puzzle. The letters may be read horizontally (left to right or right to left), vertically (from top to bottom or from bottom to top), or diagonally (at an angle). Be sure to check off the words as you find them. The first word is done for you.

### WORDS:

- ✓ OBEY
- SARAH
- GOMORRAH
- TEST
- ABRAHAM
- SODOM
- ISAAC
- SALT
- LOT
- HARAN
- CANAAN

G	E	S	F	T	G	L	Z	I	F
O	C	T	P	O	N	B	S	S	I
M	A	S	B	H	A	Y	O	A	D
O	M	E	Y	A	R	R	D	L	W
R	Y	T	C	R	A	L	O	T	A
R	A	B	R	A	H	A	M	V	E
A	P	S	W	S	N	Q	U	X	R
H	Z	H	J	I	S	A	A	C	O
D	B	K	N	N	F	G	A	J	F
M	M	S	T	R	A	P	P	N	N

---

# YOUTH

LEVEL 2

---

# BIBLE

---

# LESSONS

LESSON 7

---

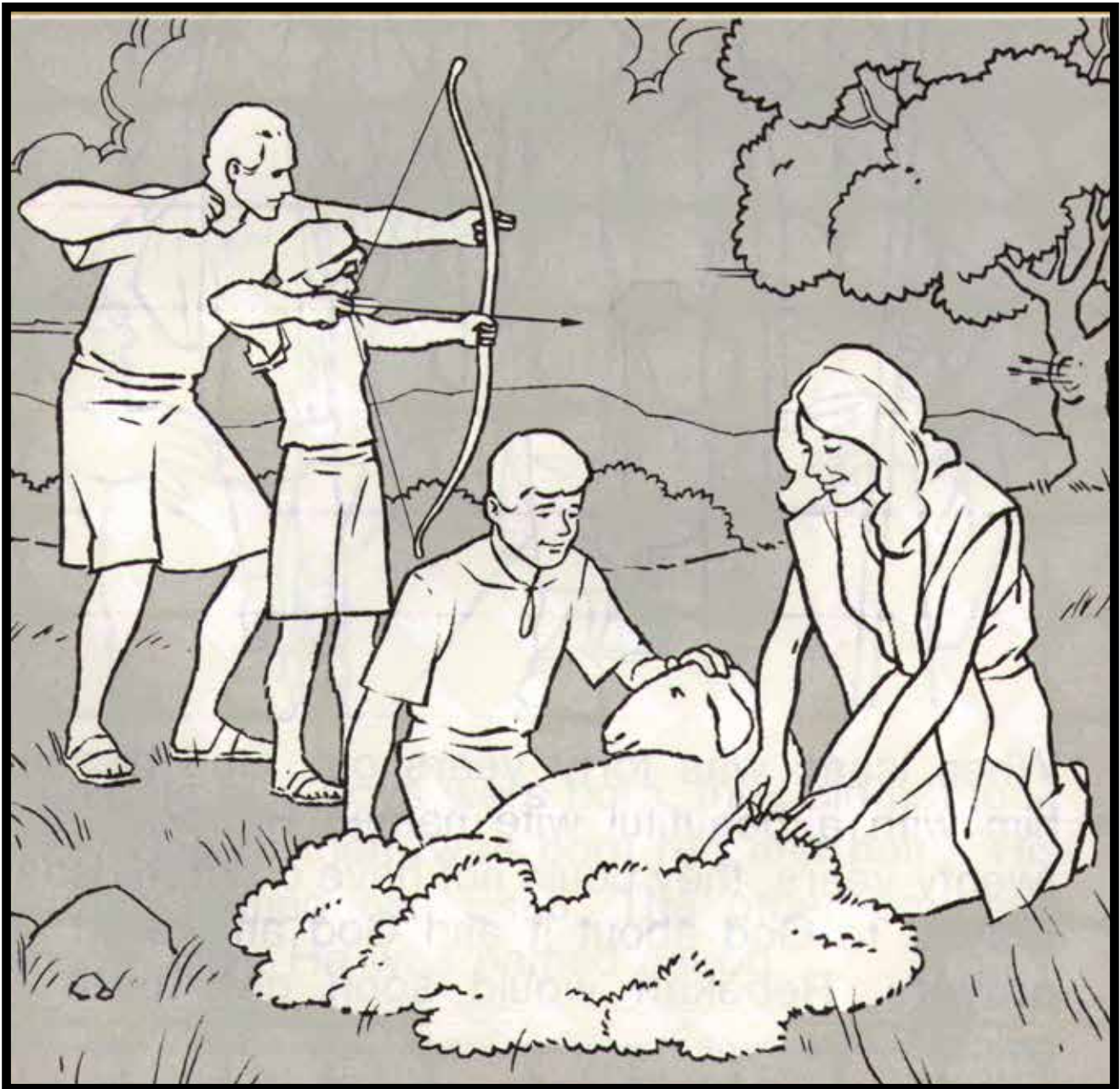

Esau and Jacob



When Isaac was forty years old, God blessed him with a beautiful wife named Rebekah. For twenty years, they could not have children. Isaac prayed to God about it and God answered his prayers. Rebekah would soon give birth to twins!

---

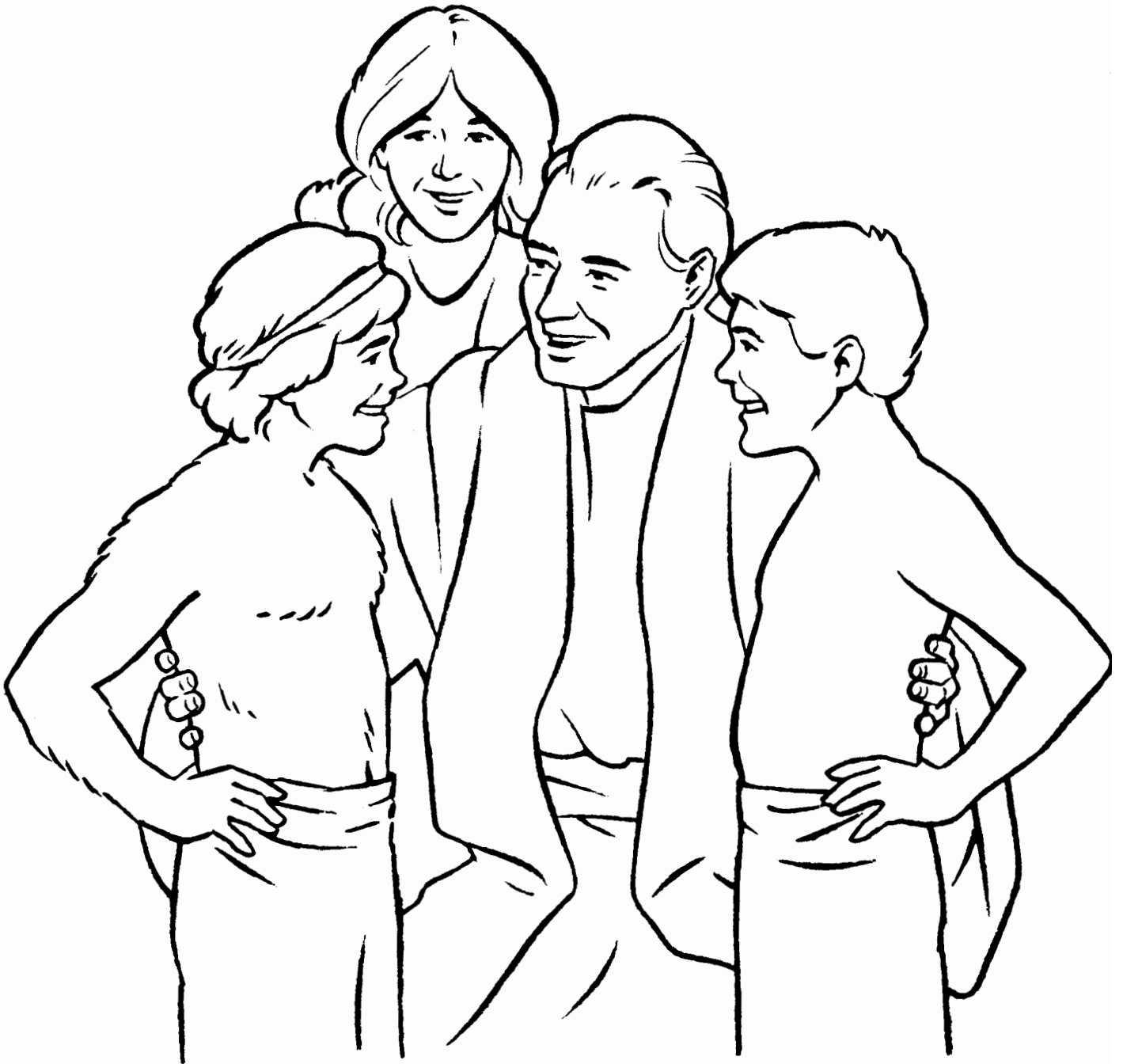

When the twin boys were born, they did not look alike. One of them was born red and hairy. His parents named him Esau. The other boy had smooth skin. He was named Jacob.

---

Parents: Explain to your child that Esau and Jacob would become the fathers of two different nations.

---

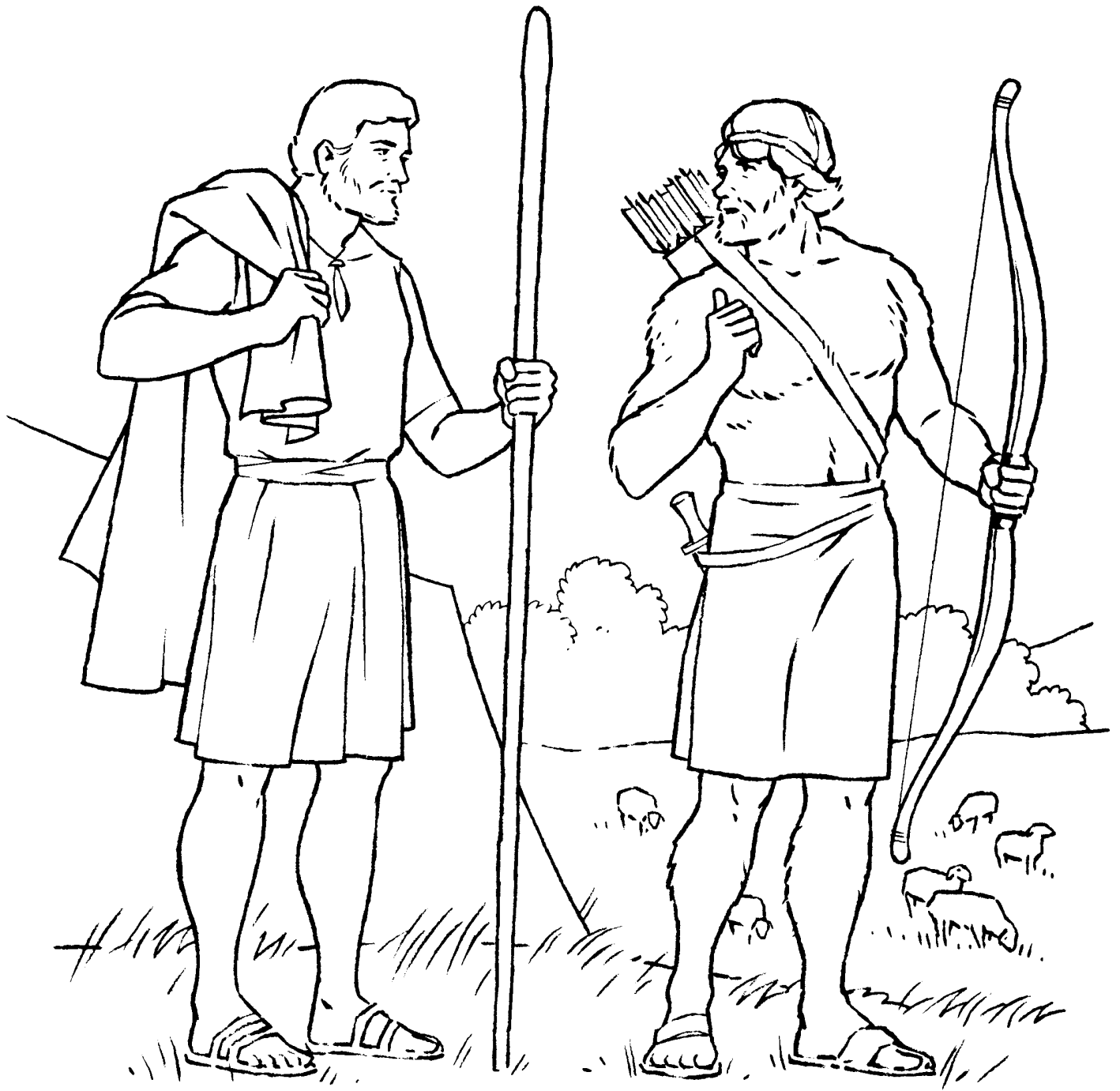

As the boys grew, Esau became a hunter and spent much of his time out in the woods. Jacob liked to live in tents and look after the sheep.



One day Esau came home from one of his hunting trips, very tired and hungry. He saw some soup that Jacob had just made. When Esau asked for some, Jacob said he could have some if he would sell his **birthright**. Since Esau thought he would die without the food, he could not see what good his right to his father's wealth would be. So Esau sold his birthright to Jacob for the soup.

---

Parents: Explain to your child what the birthright was and that Esau had it because he was the firstborn. Also explain why it was wrong for Jacob to ask Esau to sell his birthright for the soup, and why it was wrong for Esau to have sold it.

---



When Isaac was old and blind and thought he might die soon, he called Esau to him. “Go out and hunt some **venison** for one of my favorite meals,” Isaac said. “I will then bless you.” Rebekah heard what Isaac told Esau. She wanted Jacob, her favorite son, to receive the blessing instead.

---

Parents: Explain the meaning of venison. Also, ask your child why Isaac was going to bless Esau.

---



Rebekah wanted to trick Isaac into blessing Jacob while Esau was away. She first sent Jacob out to kill two young goats. She cooked the meat and then helped Jacob put the goat skins on his hands and neck so his skin would feel hairy like Esau's. They hoped this would make Isaac believe Jacob was Esau.

---

Parents: Ask your child why Rebekah wanted Jacob to receive the blessing. Explain why Jacob's and Rebekah's actions were wrong.

---





“Here is the meal you asked me for,” Jacob lied to his father. “Now bless me as you promised.”

“This is the voice of Jacob,” Isaac said. “Come closer that I may touch you.”

---



When Isaac touched Jacob's hands, he was sure they were Esau's. So when Isaac finished eating, he blessed Jacob. He said, "May God give you well-watered fields that will grow much food. Let people serve you and nations bow down to you. May a curse be on those who curse you and may a blessing be on those who bless you."

After the blessing, Jacob left his father. A few moments later, Esau returned with the meal he had prepared for Isaac. Esau was very angry when he learned that Jacob had tricked his father and stolen the blessing. Esau decided he would kill his brother after his father died.

---

Parents: Explain to your child the significance of the blessing and what it meant for Jacob's descendants.

---



Rebekah learned of Esau's plan to kill Jacob. She asked Isaac to send Jacob far away to find a wife where her brother Laban lived. Since Isaac did not want his sons to marry women from Canaan, he agreed.

---

Parents: Explain to your child why Isaac did not want his sons to marry women from Canaan.

---

## COMMANDMENT CODE

To discover some of the Ten Commandments that were broken by tricking Isaac, figure out the math problems below and write the answers on the stone tablets. The answer shows the number of a commandment that was broken.

$$\begin{array}{ccccccccccc} \boxed{6} & - & \boxed{1} & = & \boxed{\phantom{00}} & + & \boxed{3} & = & \boxed{\phantom{00}} & - & \boxed{7} & = & \boxed{\phantom{00}} & + & \boxed{4} & = & \boxed{\phantom{00}} \end{array}$$

---

$$\begin{array}{ccccccccccc} \boxed{2} & + & \boxed{3} & = & \boxed{\phantom{00}} & - & \boxed{1} & = & \boxed{\phantom{00}} & + & \boxed{3} & = & \boxed{\phantom{00}} & + & \boxed{1} & = & \boxed{\phantom{00}} \end{array}$$

---

$$\begin{array}{ccccccccccc} \boxed{2} & - & \boxed{1} & = & \boxed{\phantom{00}} & + & \boxed{8} & = & \boxed{\phantom{00}} & - & \boxed{2} & = & \boxed{\phantom{00}} & + & \boxed{2} & = & \boxed{\phantom{00}} \end{array}$$

---

$$\begin{array}{ccccccccccc} \boxed{5} & - & \boxed{5} & = & \boxed{\phantom{00}} & + & \boxed{3} & = & \boxed{\phantom{00}} & + & \boxed{6} & = & \boxed{\phantom{00}} & + & \boxed{1} & = & \boxed{\phantom{00}} \end{array}$$

---

Parents: Explain these commandments to your child, and how they were broken by some of the people mentioned in this lesson.

---

**BIBLE MEMORY** Ephesians 6:1-3

**SCRAMBLED NAMES**

Unscramble the following words to spell out the names  
 of the people you learned about in this lesson.

- AIACS      \_ \_ \_ \_ \_
- COBAJ     \_ \_ \_ \_ \_
- USEA      \_ \_ \_ \_ \_
- EKREAHB   \_ \_ \_ \_ \_
- BLANA     \_ \_ \_ \_ \_

**MYSTERY CODE**

To discover the subject of our next lesson,  
 break the secret code below.

\_ \_ \_    \_ \_ \_    \_ \_ \_    \_ \_ \_    \_ \_ \_    \_ \_ \_    \_ \_ \_    \_ \_ \_    \_ \_ \_  
 7   19   22       7   4   22   15   5   22       7   9   18   25   22   8       12   21  
  
 \_ \_ \_    \_ \_ \_    \_ \_ \_    \_ \_ \_    \_ \_ \_    \_ \_ \_    \_ \_ \_    \_ \_ \_    \_ \_ \_  
 18   8   9   26   22   15       12   9       7   19   22       7   4   22   15   5   22  
  
 \_ \_ \_    \_ \_ \_    \_ \_ \_    \_ \_ \_    \_ \_ \_    \_ \_ \_    \_ \_ \_    \_ \_ \_    \_ \_ \_  
 8   12   13   8       12   21       17   26   24   12   25

**A B C D E F G H I J K L M N O P Q R S T U V W X Y Z**  
 26 25 24 23 22 21 20 19 18 17 16 15 14 13 12 11 10 9 8 7 6 5 4 3 2 1

---

# YOUTH

---

LEVEL 2

# BIBLE

---

# LESSONS

---

LESSON 8



Jacob and His Family



Jacob began his long journey to his Uncle Laban's. As the sun began to set, he stopped to rest for the night. He slept on the ground with his head resting on a large stone.

While Jacob slept, he dreamed of a ladder that reached from earth to heaven. He saw many angels walking up and down the ladder. Standing above the ladder was God.

God spoke to Jacob and promised to give him and his **descendants** a great amount of land, including the area where he was lying. God also promised to bless and protect him.

---

Parents: Explain to your child the meaning of the **boldface** words. Also, explain that today God speaks to us through His written Word, the Bible.

---



Early the next morning, Jacob set up the large stone his head had been resting on as a **pillar** to mark the place where he had his dream. He poured oil on it and named the place Bethel, which means "House of God." Jacob then continued the long journey to his Uncle Laban's home.

---





After many days of traveling, Jacob saw shepherds in the distance bringing their flocks to a well. As Jacob spoke with the men, Laban's daughter came to the well to water her father's sheep. Her name was Rachel. She met Jacob and was excited to learn that he was her cousin. Rachel quickly ran home to tell her father. Laban was also very happy to see Jacob and invited him to stay with them.

---



During the next month, Jacob worked in Laban's fields. "What would you like to be paid for your work?" Laban asked Jacob.

"I will work seven years for you if you will then give me Rachel for my wife," Jacob said. Laban agreed.

---

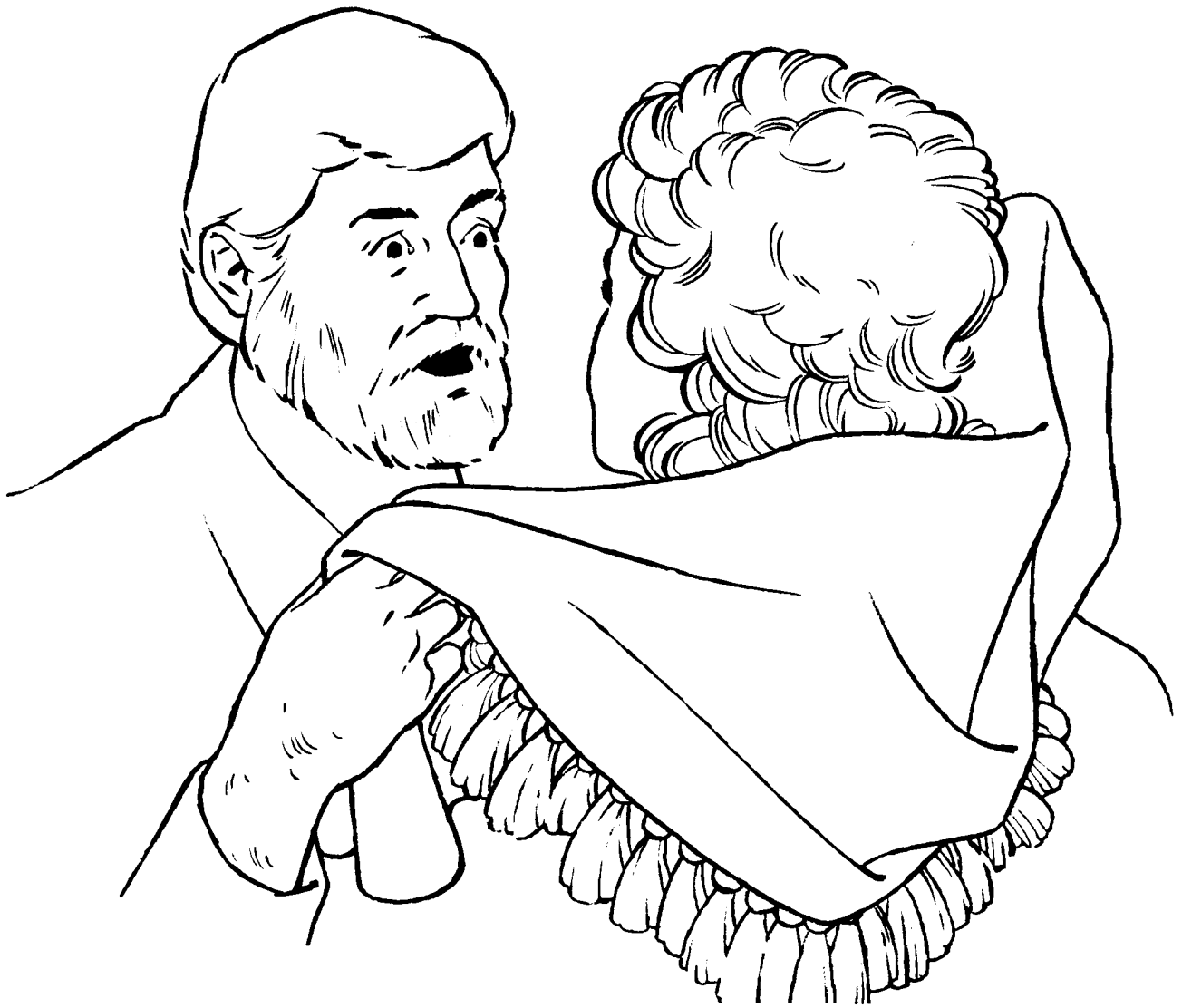

Seven years later, Jacob married. He was surprised to discover after the wedding that he had married Leah instead of Rachel! Laban had tricked Jacob into marrying his oldest daughter. Laban explained to Jacob that it was the **custom** in those days for the older daughter to marry before the younger.

Laban promised to give Rachel to Jacob at the end of the week if he would work for him seven more years. Jacob agreed.

---

Parents: Remind your child that Jacob had tricked Esau years earlier, and was now tricked himself. Also, explain that Jacob did not see the bride's face until after the wedding.

---

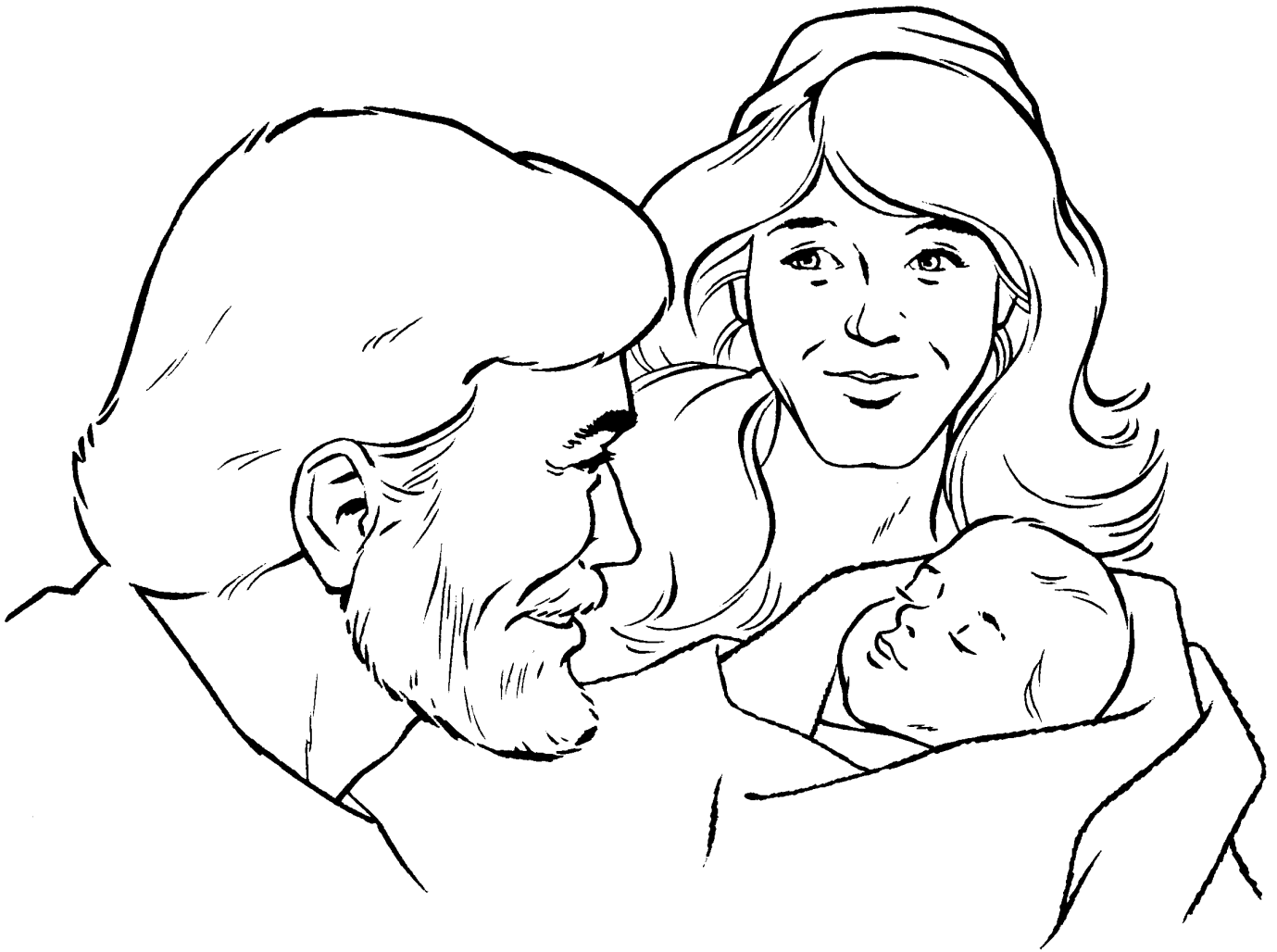

During the next several years, Leah had six sons. She named them Reuben, Simeon, Levi, Judah, Issachar and Zebulun. But Rachel was unable to have children. She decided that her maid, Bilhah, should have children for her. So Bilhah gave birth to two sons named Dan and Naphtali. Then, Leah thought that her maid, Zilpah, should also have children for her. Zilpah had two sons whom Leah named Gad and Asher. After this, God healed Rachel and she gave birth to a son whom she named Joseph.

---

Parents: Explain that the descendants of Jacob's sons have become certain nations of our twentieth century.

---



Jacob worked for Laban twenty years. During that time Jacob's family had grown very large. Jacob now wanted to return to the land of Canaan to see his aging father, Isaac. But Laban did not want him to leave. So Jacob and his family left while Laban was away **shearing** sheep.

Laban was angry when he learned that Jacob had gone. He was further angered when he discovered that some small images he prized highly were missing. Unknown to Jacob, Rachel had taken them with her and hidden them.

Laban pursued Jacob and his caravan. On the way, God warned Laban in a dream not to harm Jacob. When he arrived, Laban greeted Jacob and asked about the images. When they could not be found, the two made an agreement of friendship. After a farewell feast, Laban then returned home and Jacob continued on his way.

---

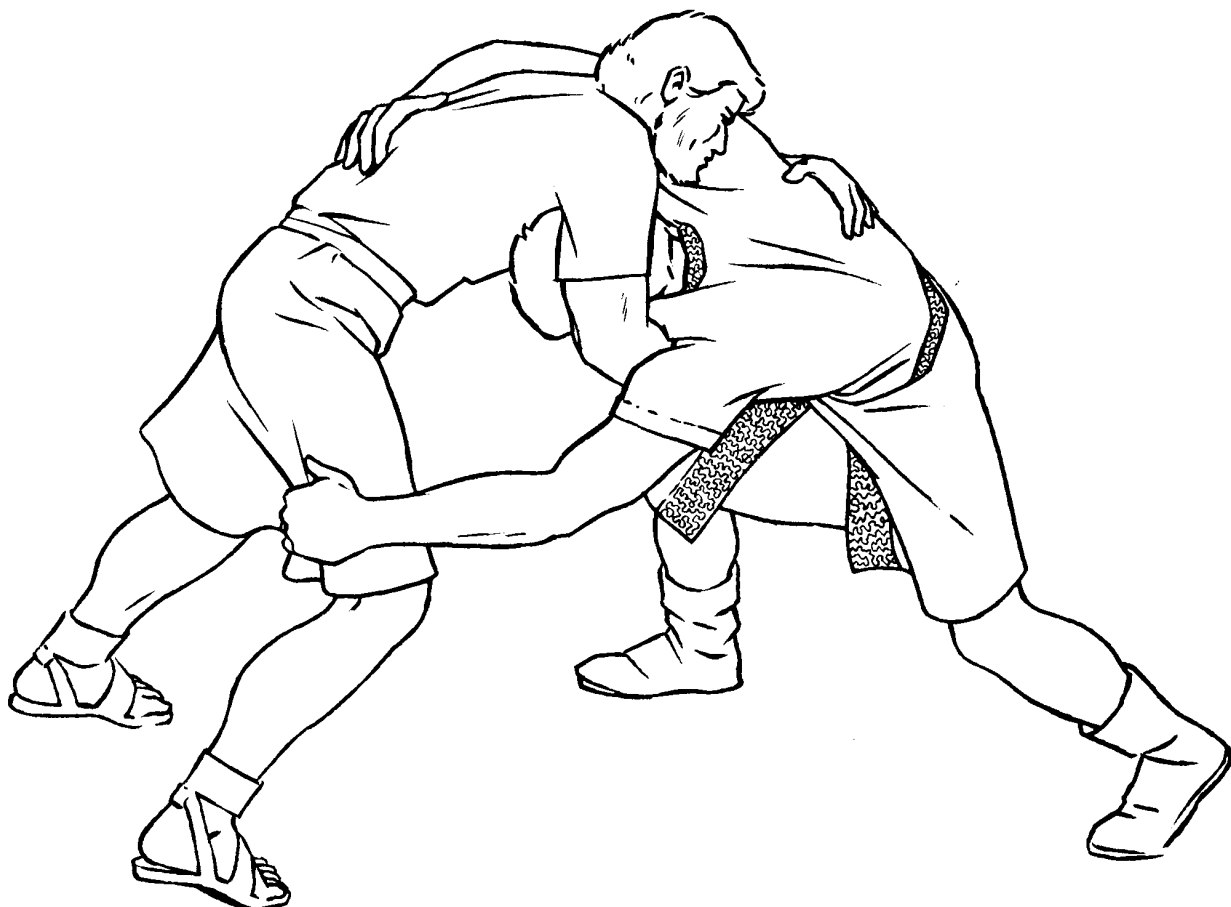

As Jacob neared the land of Canaan, he learned that Esau and a group of men were riding swiftly to meet him. Jacob feared that Esau might still want to kill him. So Jacob asked God for protection.

Before meeting, both groups camped for the night. Jacob left camp to be alone for awhile. Suddenly, somebody seized him and a wrestling match began. Soon, Jacob realized that his opponent wasn't an ordinary man. He was the Eternal, the One who later became Jesus Christ!

The two wrestled all night, but Jacob would not let go until God had blessed him. So God blessed Jacob and changed his name to Israel.

---

Parents: Explain that God changed Jacob's name to "Israel" which means champion or overcomer, because he prevailed with God.

---

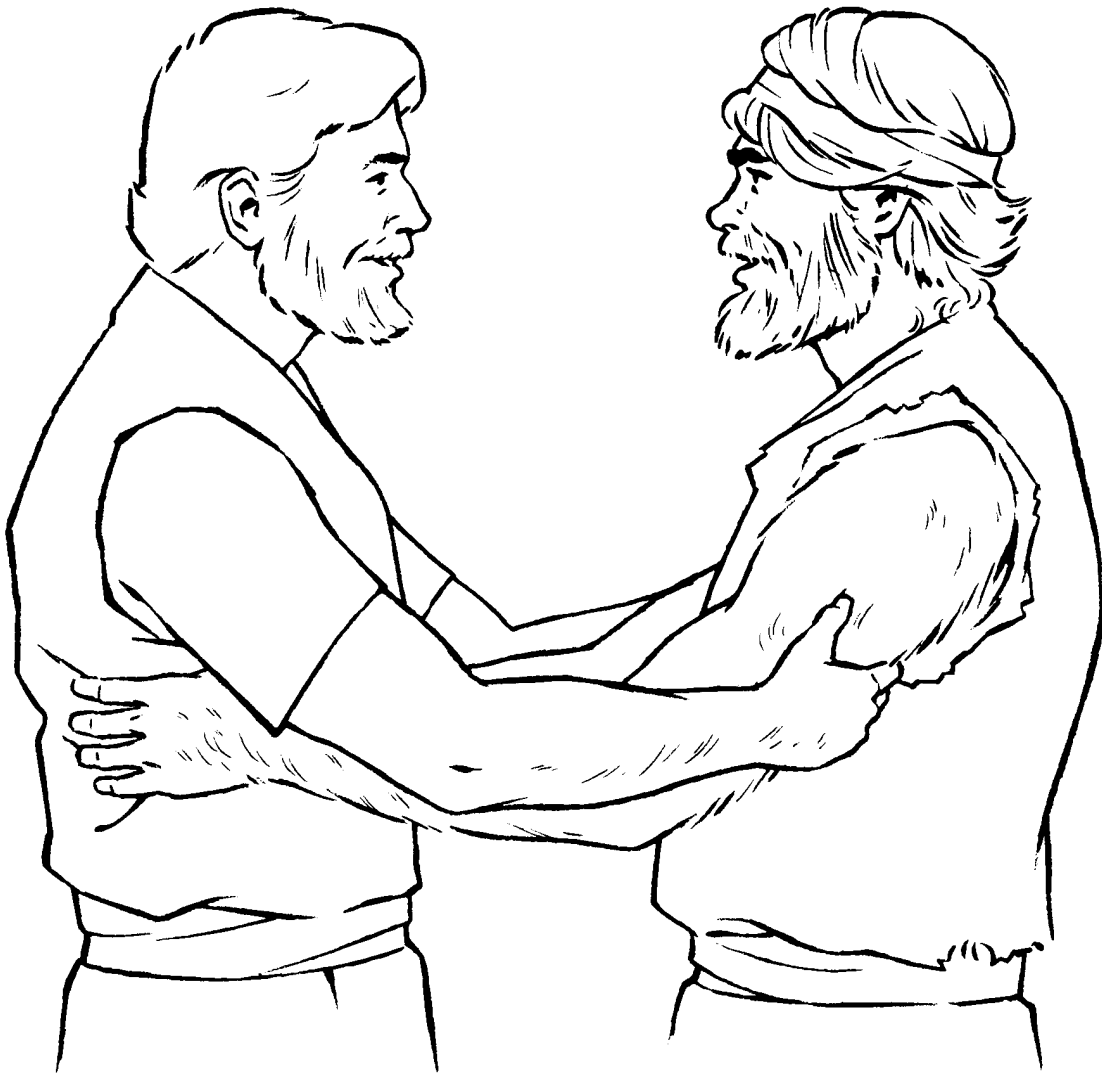

The next morning, Jacob could see Esau coming toward his caravan. He was very relieved to learn that Esau was glad to see him. After their happy reunion, Jacob continued on to where Isaac lived. On the way, Rachel gave birth to Jacob's twelfth son, Benjamin. It was then that Rachel died.

Not long afterwards, the trip was finally over. Jacob was very happy to see his father, Isaac, who lived to be 180 years old. Jacob and his family continued to dwell in the land of Canaan for many years.

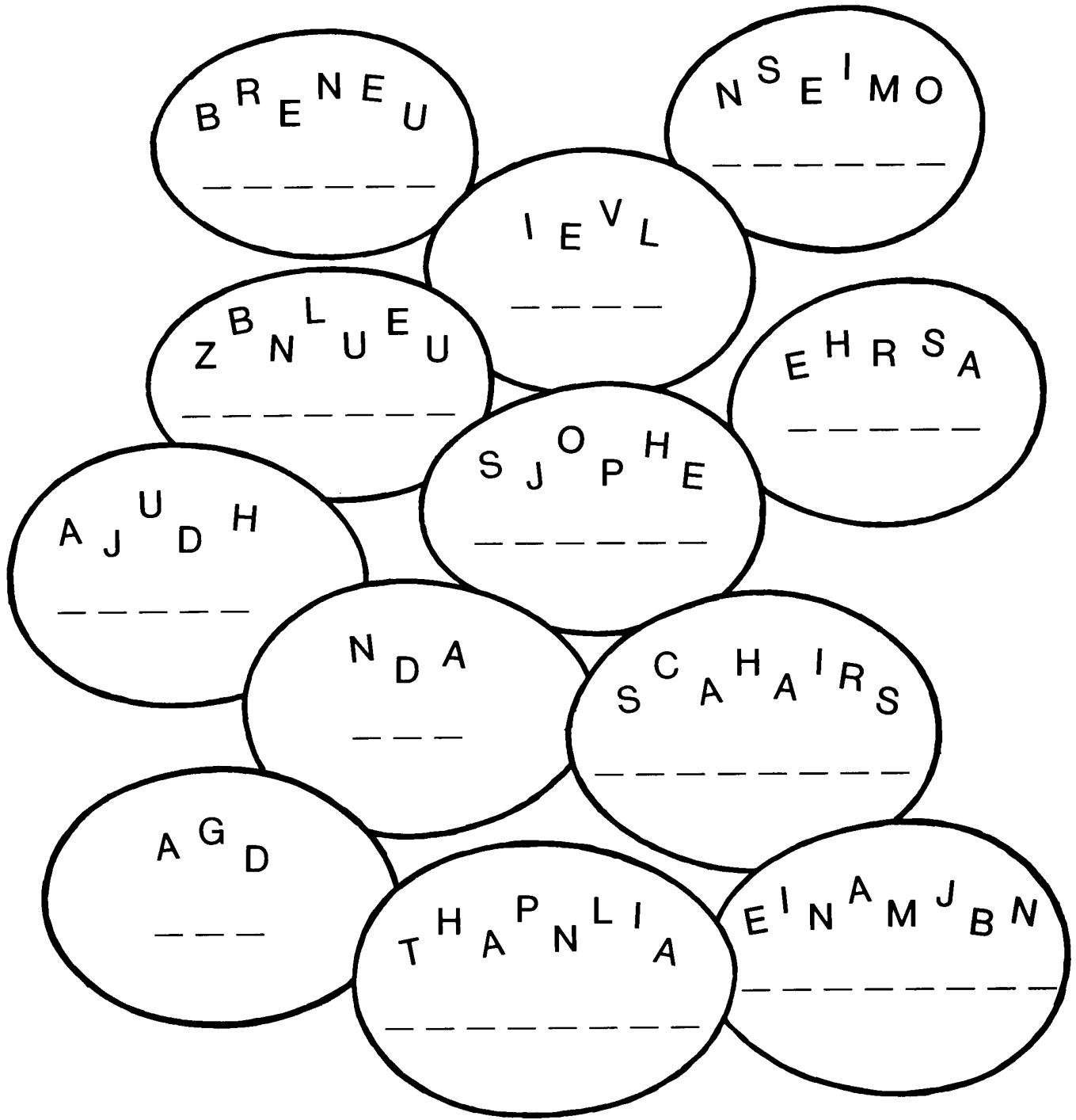

### SCRAMBLED EGGS

Unscramble the letters and write down the names of Jacob's twelve sons. If you need help, look back in this lesson to find their names.

---



**BIBLE MEMORY** Proverbs 6:16-19

**MINI-CROSSWORD**

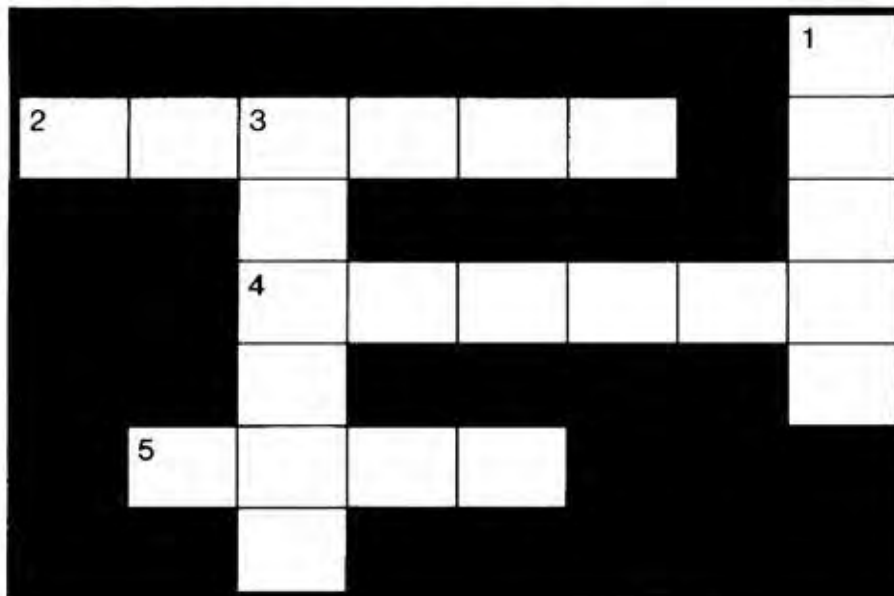

**Across**

2. Jacob's name was changed to \_\_\_\_\_.
4. Jacob returned to the land of \_\_\_\_\_ to see his father Isaac.
5. Rachel's older sister.

**Down**

1. Jacob slept on a large \_\_\_\_\_ when he had his dream.
3. Joseph's mother.

---

# YOUTH

---

LEVEL 2

---

# BIBLE

---

# LESSONS

---

LESSON 9

---

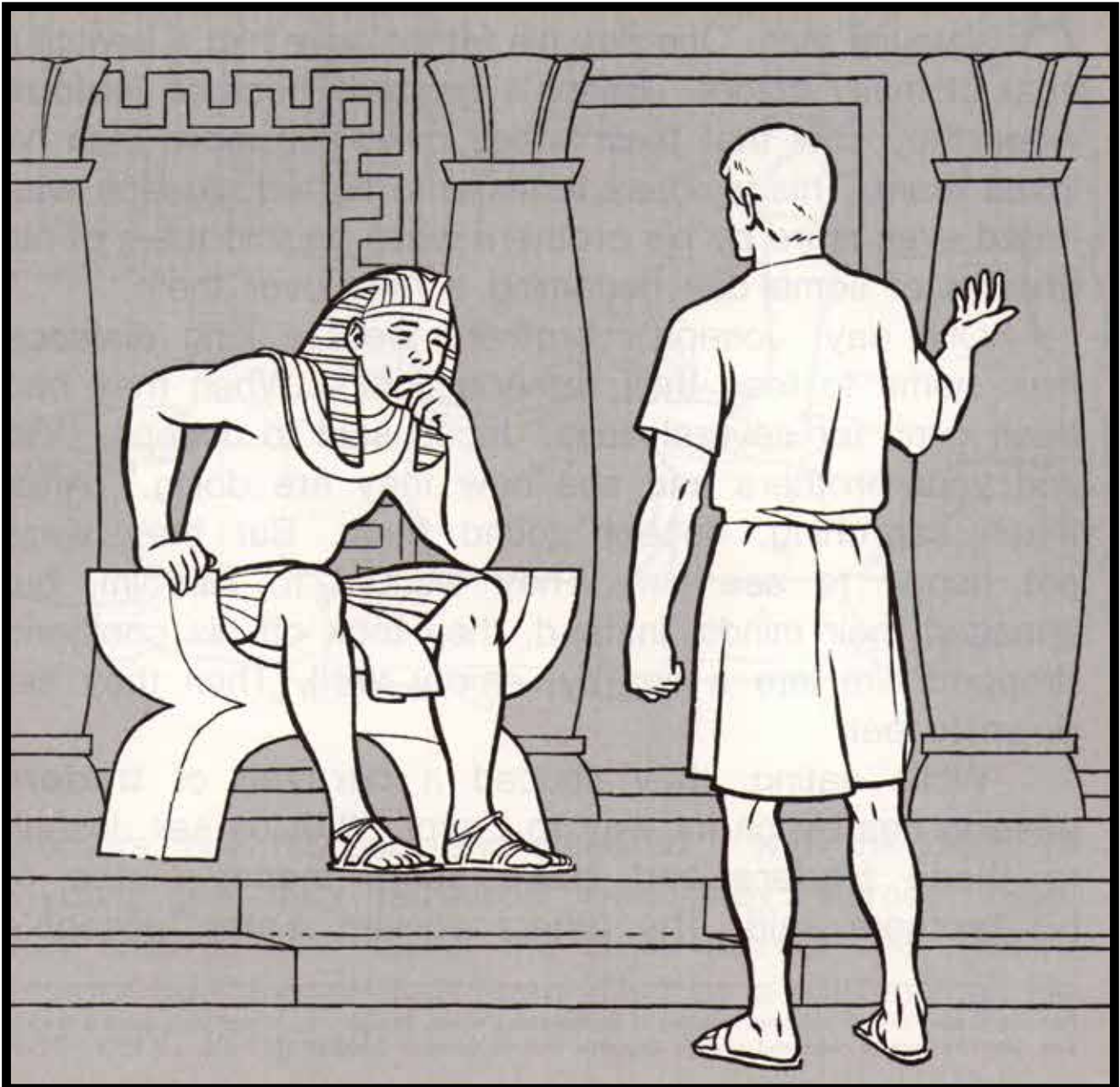

Joseph's Adventures in Egypt

---

---

# JOSEPH'S ADVENTURES IN EGYPT

---

As time passed, Joseph, Jacob's favorite son, grew into a young man. One day his father gave him a beautiful coat of many colors. Joseph's brothers became very jealous when they saw that their father loved him more than he loved them. This jealousy turned into hatred. Joseph was hated even more by his brothers when he told them of his dreams of some day becoming an important person.

One day Joseph's brothers went a long distance from home to feed their father's flocks. When they had been gone for several days, Jacob said to Joseph, "Go find your brothers and see how they are doing." After much searching, Joseph finally found them. But they were not happy to see him. They wanted to kill him, but changed their minds. Instead, they took off his coat and dropped him into a nearby, empty **well**. Then they sat down to eat.

While eating, they noticed a **caravan** of traders passing nearby on its way to Egypt. "Let's sell Joseph to these traders and make some money," one of his brothers suggested. They agreed. Later, Joseph's brothers took his

---

Parents: Explain to your child the meaning of the **boldface** words. Explain why Joseph was Jacob's favorite son. Also, be sure to read and explain Joseph's dreams found in Genesis 37.

---

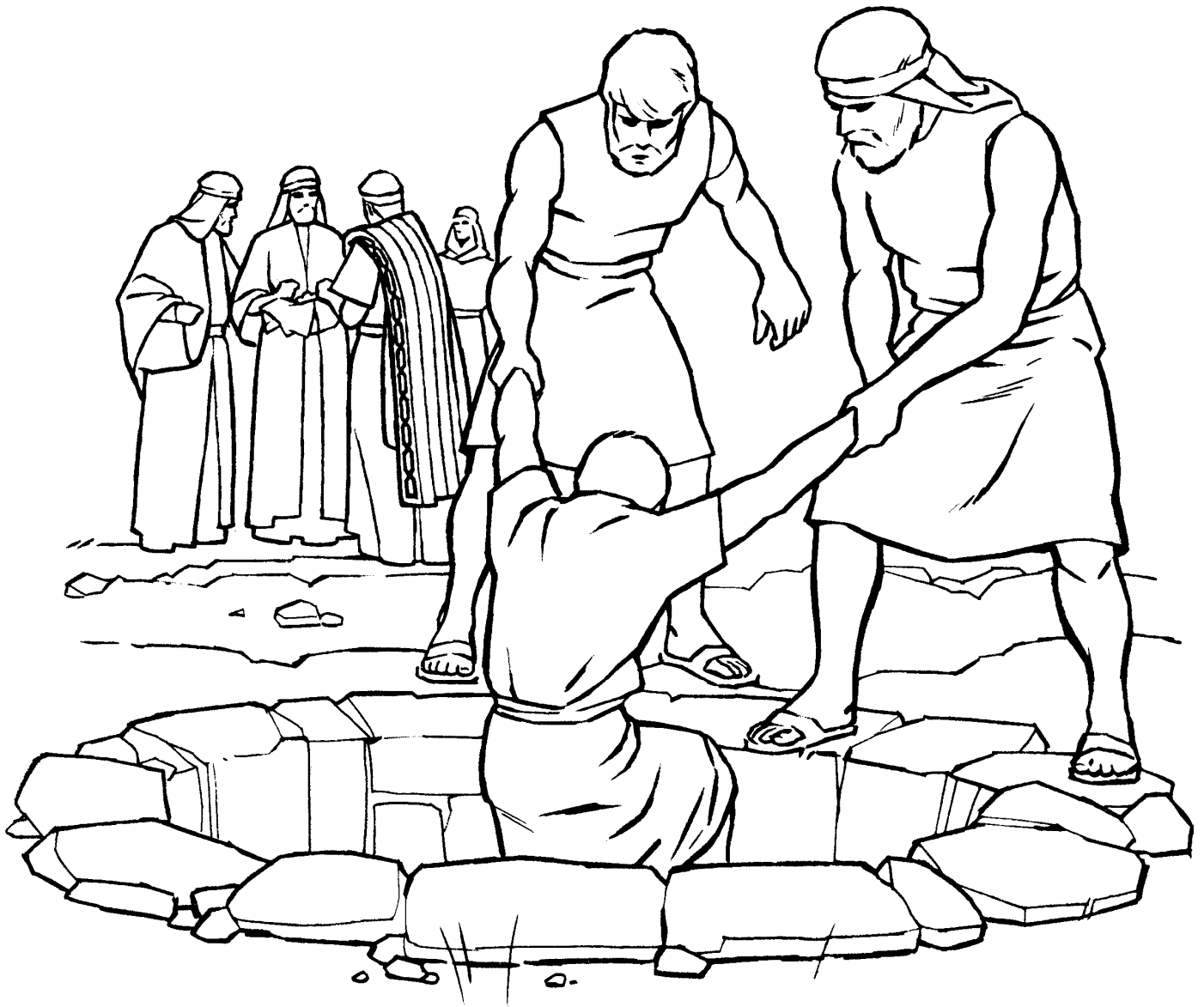

coat and smeared it with the blood of a young goat they had killed. When they returned home, they showed their father the blood-stained coat. Jacob concluded that Joseph had been killed by a wild animal. He was very, very sad.

---

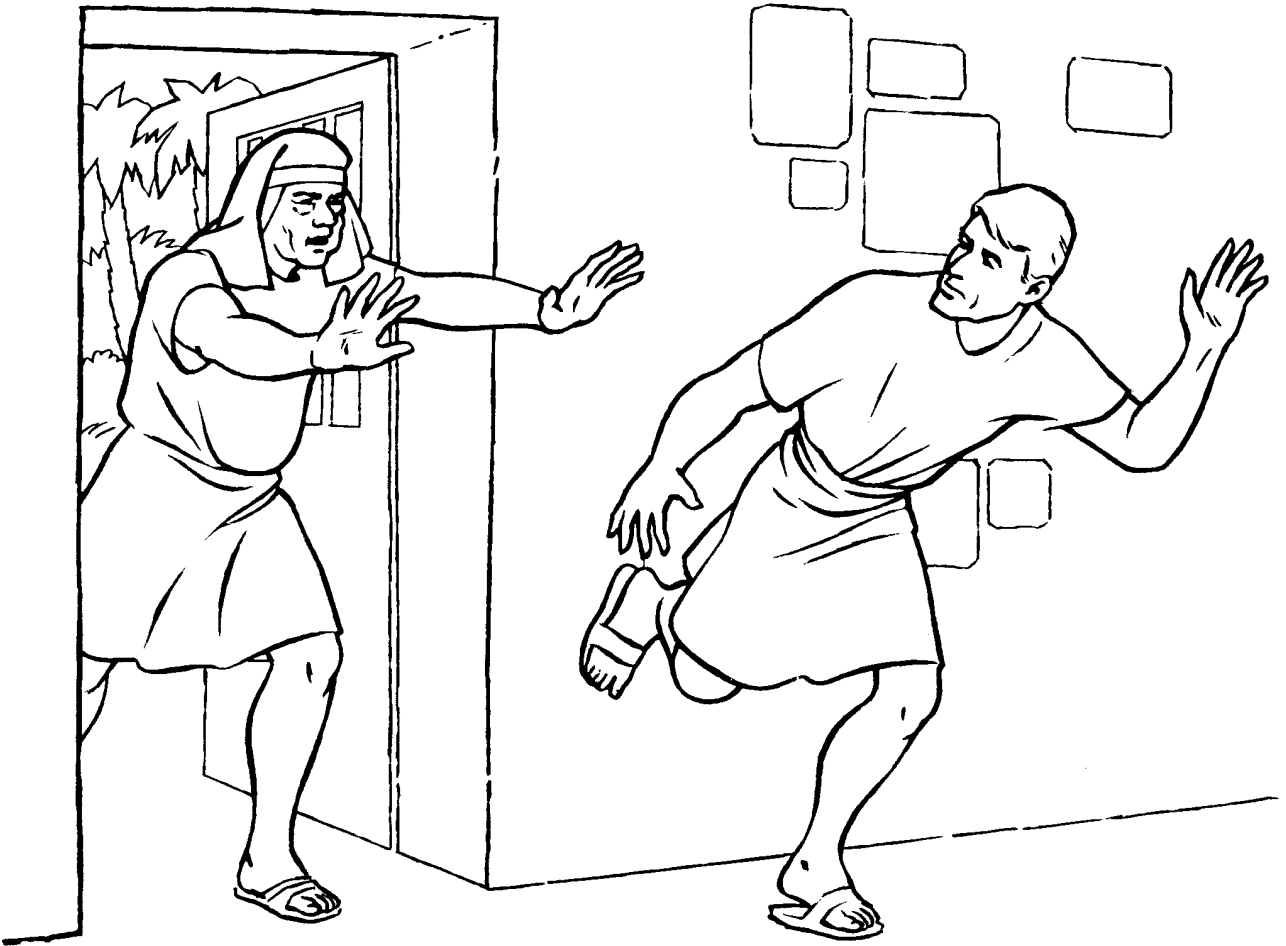

When the traders arrived in Egypt, they sold Joseph to a man named Potiphar. He was an **officer** of Pharaoh, king of Egypt. Potiphar soon learned that Joseph was a hard worker and could be trusted. So he put Joseph in charge of all the servants in his house. God was blessing Joseph in all that he did because he kept His commandments.

Joseph continued to serve his master well until Potiphar's wife **falsely accused** him of trying to harm her. Potiphar believed her lie and had Joseph put in prison. In time, the keeper of the prison put Joseph in charge of all the prisoners.

---

Parents: Explain to your child why the keeper of the prison put Joseph in charge of all the prisoners.

---

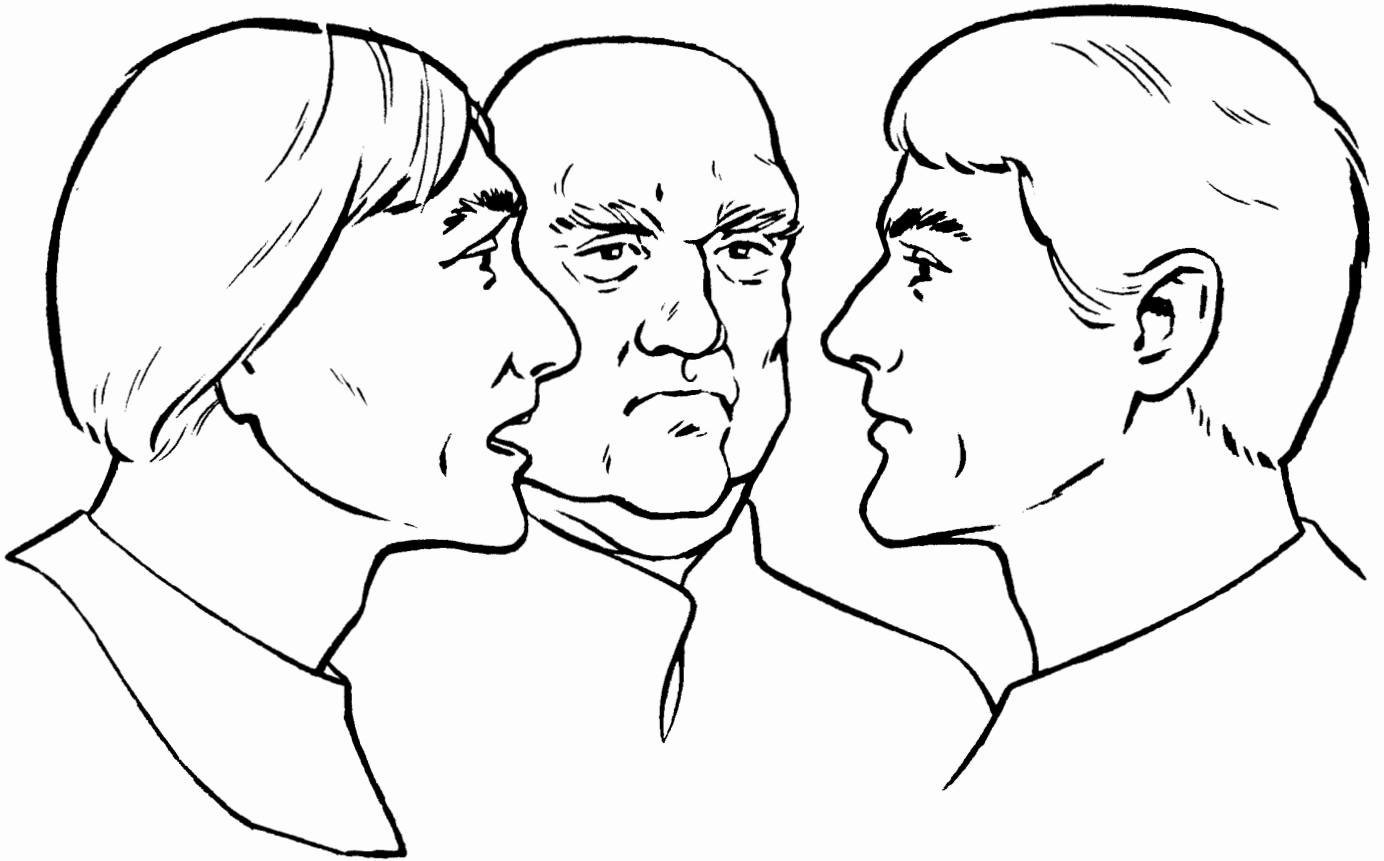

Later, Pharaoh's **butler** and **baker** were put in the prison. One night each of them had a dream. When they awoke the next morning, they were both very sad. Joseph noticed this and asked, "Why are you both so sad?" The butler and the baker then told him of their dreams.

God helped Joseph explain the meaning of their dreams. The dreams came to pass just as Joseph had said. The butler returned to work for Pharaoh and the baker was hanged. Joseph asked the butler to tell Pharaoh that he was unjustly put in prison. But the butler was so happy to be free, he forgot all about Joseph.

---

Parents: Tell your child about the dreams of the butler and baker. Also, mention that Joseph gave God the credit for interpreting the dreams.

---



Two years later, while Joseph was still in prison, Pharaoh had two dreams that worried him. None of his wise men could tell him the meaning of his dreams. Then the butler remembered how Joseph had told the meanings of his and the baker's dreams. So he told Pharaoh about Joseph.

“Have him brought before me at once!” ordered Pharaoh. Joseph was soon standing before the king of Egypt. With God's help, he told Pharaoh the meaning of his dreams. “There will be seven years of good crops followed by seven years of terrible **famine**,” he said.

Pharaoh believed Joseph, and decided to put him in charge of storing grain for the coming famine. Pharaoh also made Joseph governor, or ruler, of all Egypt under him. God was greatly blessing Joseph because of his continued obedience.

---

Parents: Tell your child about Pharaoh's dreams. Remember that both dreams had the same meaning.

---



During the seven good years, much grain was stored. Then came the famine. When people ran out of food, they went to Joseph who sold them the grain they needed. The famine was very great in the land of Canaan. Being low on food, Jacob sent ten of his sons to Egypt to buy some grain. He kept his youngest son Benjamin at home for fear of losing him as he had Joseph several years earlier.

Joseph recognized his brothers when they came and bowed before him, but they did not recognize him. He wanted to welcome them, but decided to be harsh for a while to teach them a lesson. Joseph accused his brothers of being spies, and then had them put in prison. After three days, he freed the brothers, except for Simeon, and let them return home. Simeon would be kept in Egypt until the others returned with Benjamin.

---



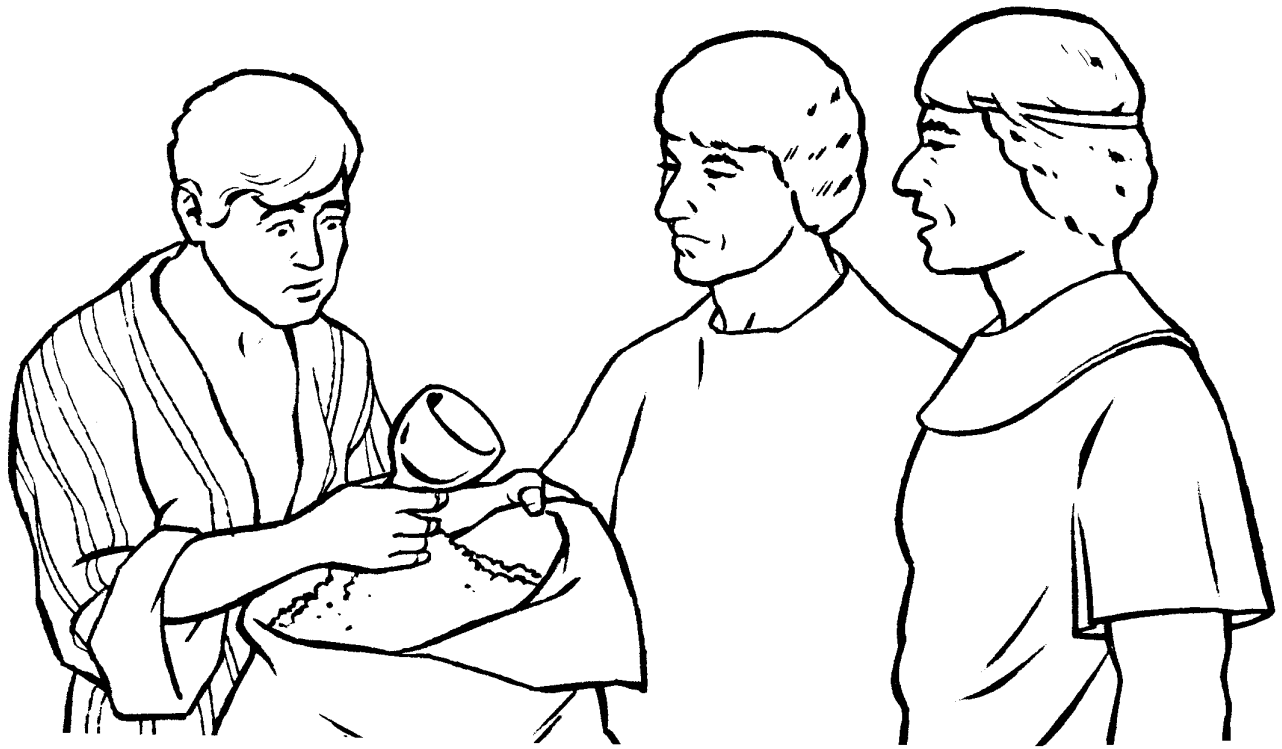

Joseph's brothers returned home and told their father all that happened. "The Egyptian governor wants us to take Benjamin to Egypt so that he may see him," they said. But Jacob said he would not let Benjamin go. The famine grew worse and they needed more food. Jacob had no other choice but to send Benjamin along with his other sons to buy more grain.

When they arrived, Joseph invited his brothers to eat with him. But he still did not tell them who he was. The next day they received their grain and started home. Soon they were overtaken by men on horses. The leader was Joseph's chief servant. "Why have you stolen the governor's favorite silver cup?" he demanded.

"We are not thieves," they explained. But after a search was made, the cup was found in Benjamin's sack of grain. Earlier, Joseph had the silver cup placed in Benjamin's sack. Now the brothers would have to return to Egypt.



Looking at his fearful brothers, Joseph pointed at Benjamin and said, “You will stay here and be my servant. The rest of you may return home.” Then Judah, the brother responsible for Benjamin, pleaded, “Our father will die of sorrow if Benjamin does not return with us.”

Joseph was unable to hold back his true **identity** from his brothers any longer. With tears streaming down his face, he cried out, “I am Joseph your brother, whom you sold!” His brothers were surprised and frightened!

“Don’t be fearful,” said Joseph. “God has caused events to work out so that I would be here to help prepare for the famine. I want you to return to Canaan and bring your father, your families and all your **possessions** to Egypt.” When Jacob arrived in Egypt, there was a great celebration. He was very thankful to see Joseph alive and well.



Just before he died, Jacob adopted Joseph's two sons, Manasseh and Ephraim, as his own and blessed them. Jacob crossed his arms as he blessed his two grandsons, asking God to give the greater blessing to Ephraim, the younger brother. Jacob then blessed his own sons, after which he died at the age of 147. His body was taken back to Canaan where he was buried.

Joseph and all his brothers and their families continued to live in Egypt. There they grew great in number. Joseph continued to live a full and eventful life with God's blessing until his death at the age of 110.

---

Parents: Explain to your child who the modern-day descendants of Ephraim and Manasseh are. Also, explain why Jacob crossed his arms when blessing his grandsons.

---

---

## FILL IN THE BLANKS

Fill in the blanks below with the correct words. You may use the WORD BANK at the bottom of the page to help you spell the missing words.

1. Joseph's father, Jacob, gave him a \_\_\_\_\_ of many \_\_\_\_\_.
2. Potiphar had Joseph put in \_\_\_\_\_.
3. Pharaoh's dreams meant there would be \_\_\_\_\_ years of good crops followed by seven years of \_\_\_\_\_.
4. Joseph became ruler of \_\_\_\_\_ under Pharaoh.
5. God \_\_\_\_\_ Joseph because he kept His commandments.
6. Jacob and his \_\_\_\_\_ moved to Egypt where they grew great in number.

## WORD BANK

PRISON	FAMINE	FAMILY	SEVEN
COLORS	BLESSED	COAT	EGYPT

**BIBLE MEMORY** Ephesians 6:1-3

### MATH PUZZLE

Solve the math problems below. Then match each number answer to the correct letter at the bottom of the page. Write the letters in the boxes. The letters will spell the name of one of Jacob's sons.

	<u>5</u>	<u>3</u>	<u>6</u>	<u>3</u>	<u>4</u>	<u>4</u>
+	<u>5</u>	<u>4</u>	<u>6</u>	<u>2</u>	<u>4</u>	<u>2</u>
=						
	↓	↓	↓	↓	↓	↓
	<input type="text"/>	<input type="text"/>	<input type="text"/>	<input type="text"/>	<input type="text"/>	<input type="text"/>

1 2 3 4 5 6 7 8 9 10 11 12 13 14

A C B N E H O P D J F S T G

---

# YOUTH

---

LEVEL 2

---

# BIBLE

---

# LESSONS LESSON 10

---



Moses Is Called by GOD

---

# MOSES IS CALLED BY GOD

---

**A**fter the death of Joseph and his brothers, their families continued to live in the land of Egypt. There they became known as **Israelites**.

After many years, a new Pharaoh became king of Egypt. He was very mean to the people of Israel. He was afraid of the many Israelites who lived in the part of Egypt called **Goshen**.

Pharaoh made slaves of the Israelites. He made them work very hard for harsh Egyptian **taskmasters**. Pharaoh did this to keep the Israelites from having more children. But the harder the Israelites worked, the more children they had.

Pharaoh then ordered the **midwives** to kill all the newborn baby boys. But the midwives did not obey Pharaoh. Instead, they chose to obey God and not kill them. God blessed the midwives for their obedience and gave them houses to live in.

The Israelites were very unhappy. Each day they would make bricks for Pharaoh's buildings. The taskmasters also made them work in the fields. In all that they did,

---

Parents: Explain the meaning of the **boldface** words. Discuss with your child how the Israelites came to be in the land of Egypt. Also discuss why Pharaoh made slaves of the Israelites.

---

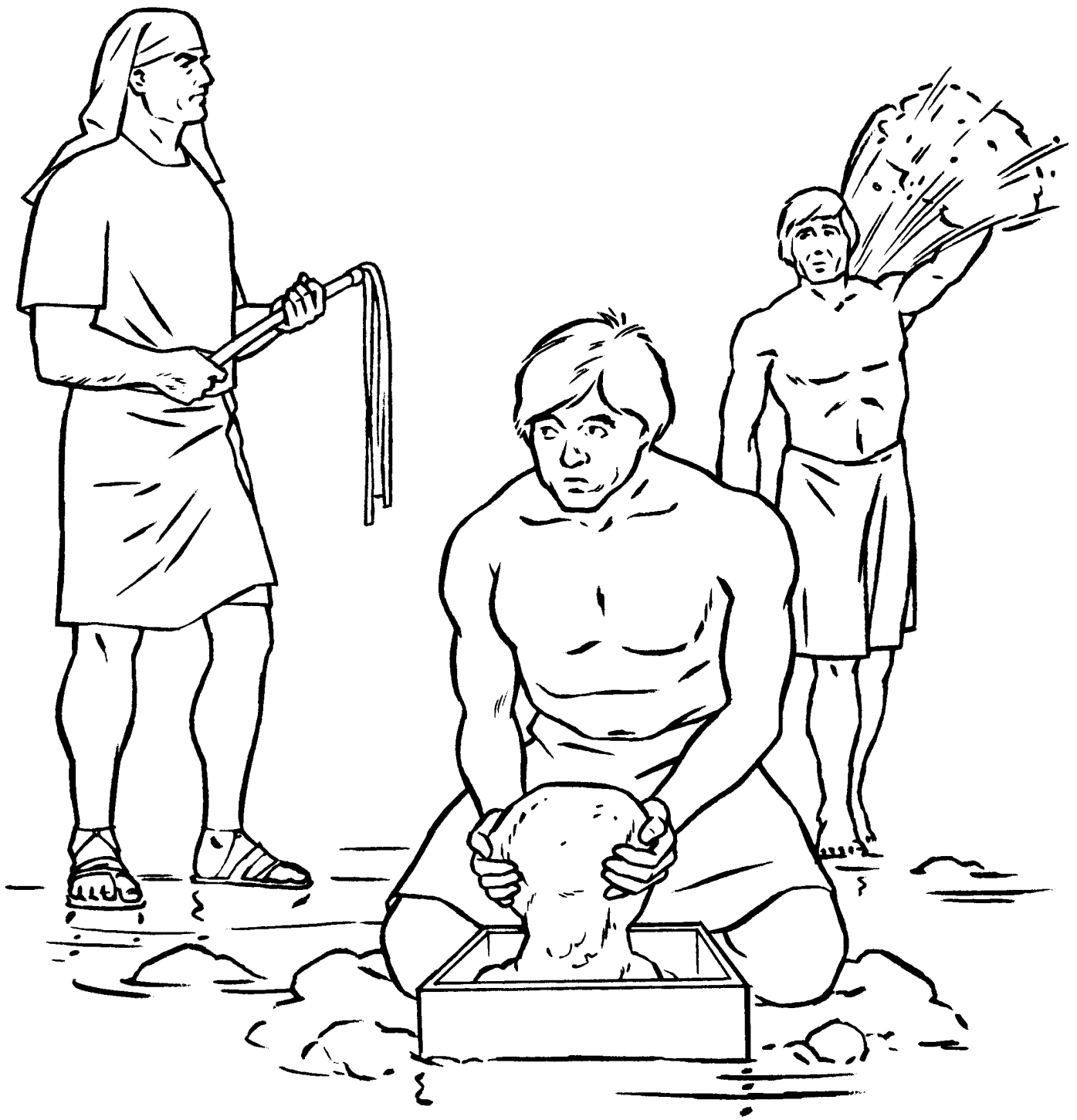

the Egyptians made them work very long and hard.

One day, an Israelite woman gave birth to a baby boy. He was a very handsome baby. His mother hid him where the Egyptian soldiers would not find him. She hid him for three months.





When she could no longer keep her son hidden, she made a small reed basket to put him in. After covering the basket with **pitch**, she carefully set it into the water at the river's edge. As the basket floated among the bulrushes, her daughter followed along to see what would happen.

The young girl soon saw Pharaoh's daughter pull the basket from the river. When Pharaoh's daughter opened the basket, she saw the baby boy inside. Quickly the

---



young girl ran to Pharaoh's daughter and asked, "Will you need someone to nurse the baby?"

"Yes, go and find an Israelite woman to nurse the child," replied Pharaoh's daughter. The young girl ran to tell her mother the good news. Now the mother could care for her own son before giving him back to Pharaoh's daughter.

Later, Pharaoh's daughter returned for the child. She took him back to Pharaoh's **court** where he would live. She named him Moses.

---



**Pharaoh's daughter finds Moses floating among the bulrushes.**

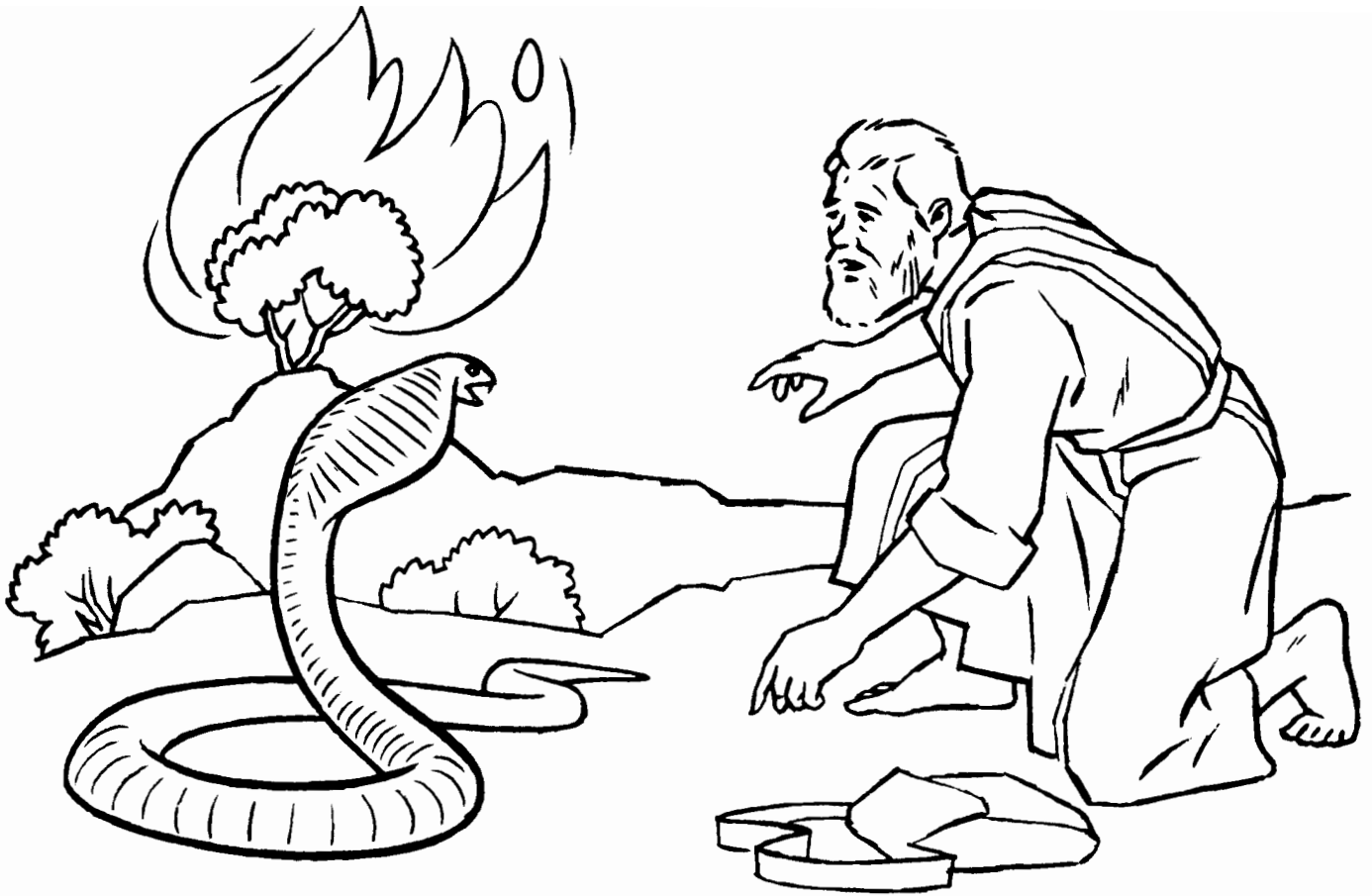

One day, while Moses tended his father-in-law's sheep near Mount Sinai, he noticed a nearby bush was on fire. As he went near, he was surprised to see that the bush was not being burned up. Then God spoke to Moses out of the burning bush. God told Moses to remove his shoes because the ground where he stood was **holy**.

"I have seen how the Egyptians have enslaved my people," God said. "I will send you to Pharaoh and you shall lead my people out of Egypt."

God also showed Moses a **miracle** that He would do before Pharaoh and the elders of Israel. "Cast your rod to the ground!" God commanded. As soon as the rod touched the ground it became a large, wiggling snake.

"Pick it up by the tail," God said. Moses slowly reached down and grabbed it by the tail. The snake became a rod in his hand.



Moses was afraid and told God that he could not speak well. So God agreed to let Moses' brother, Aaron, go with him and talk to Pharaoh.

God warned Moses that Pharaoh would not free the Israelites. God knew that He would have to perform great miracles and wonders before Pharaoh would let them go.

In our next lesson, we will learn what God did to free the Israelites.

# CROSSWORD PUZZLE

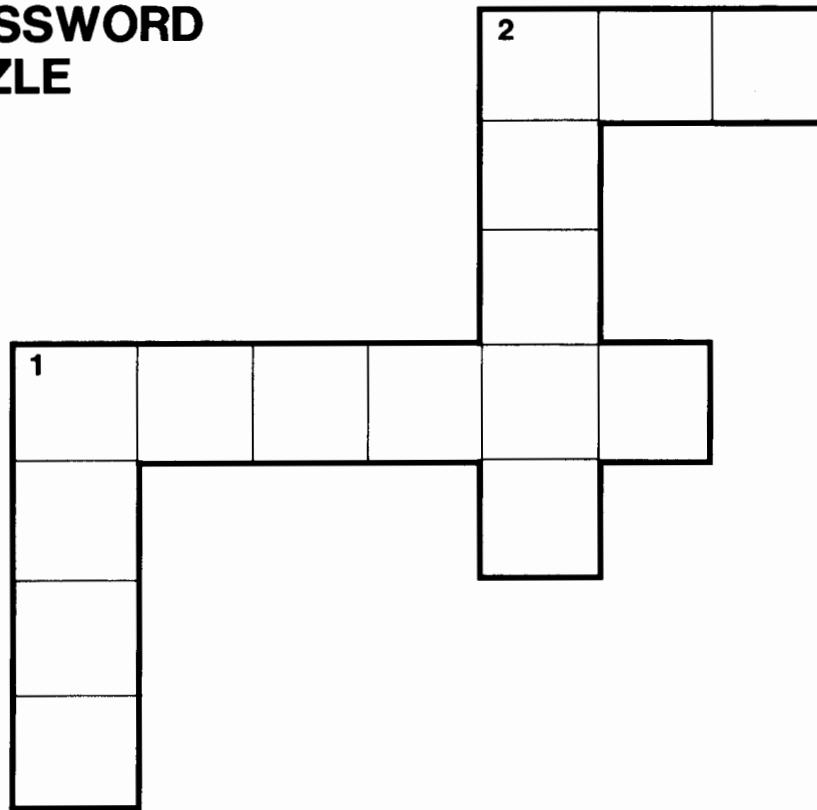

1. ACROSS

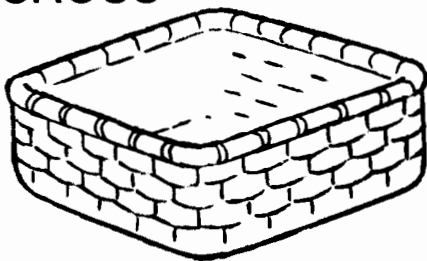

2. ACROSS

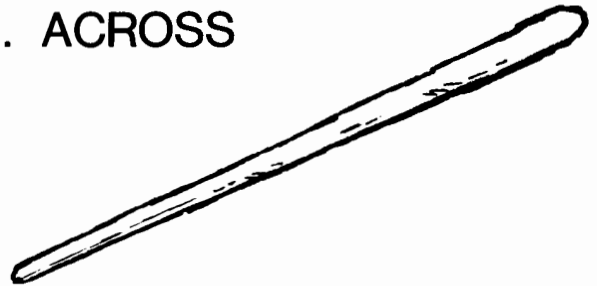

1. DOWN



2. DOWN



---

## WORD SEARCH

Find each word from the Word Bank below in the Word Search puzzle. The letters may be read from left to right or right to left, from top to bottom or bottom to top or at an angle. Be sure to check off the words as you find them.

A R F A N I L B  
Y I F O R O O B  
W R R E B U F U  
U A S C A O H L  
A T M O S E S R  
P R M D K I U U  
T P Y G E A B S  
Y I E P T E L H

## WORD BANK

MOSES

AARON

BUSH

BASKET

BULRUSH

EGYPT

---

## SCRAMBLED PUZZLE

Unscramble the letters and pictures to find words from this lesson.

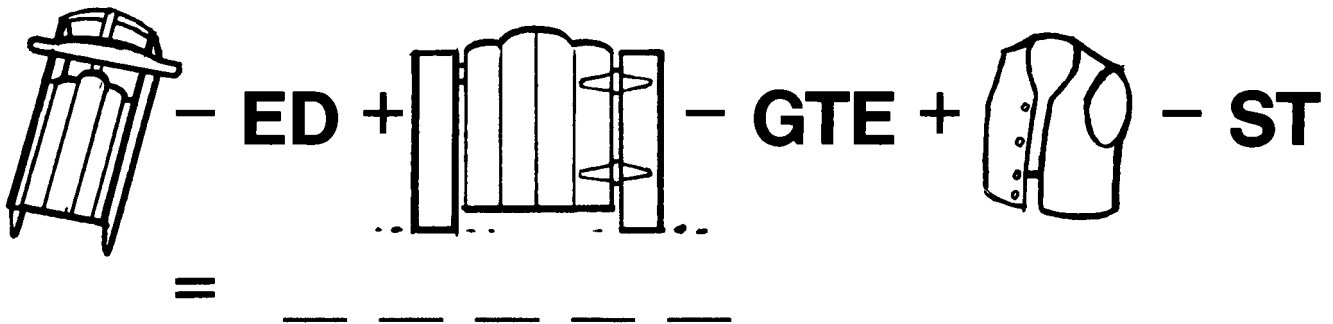
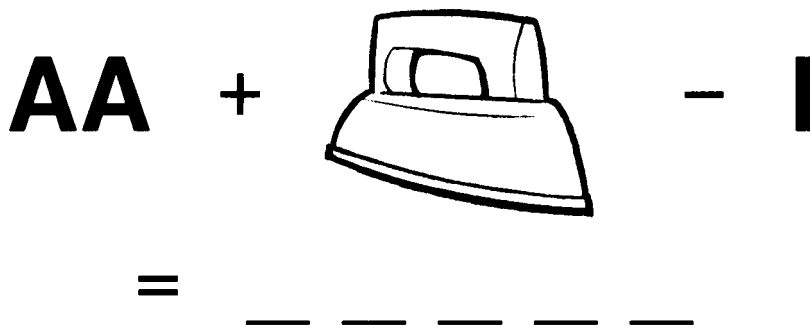
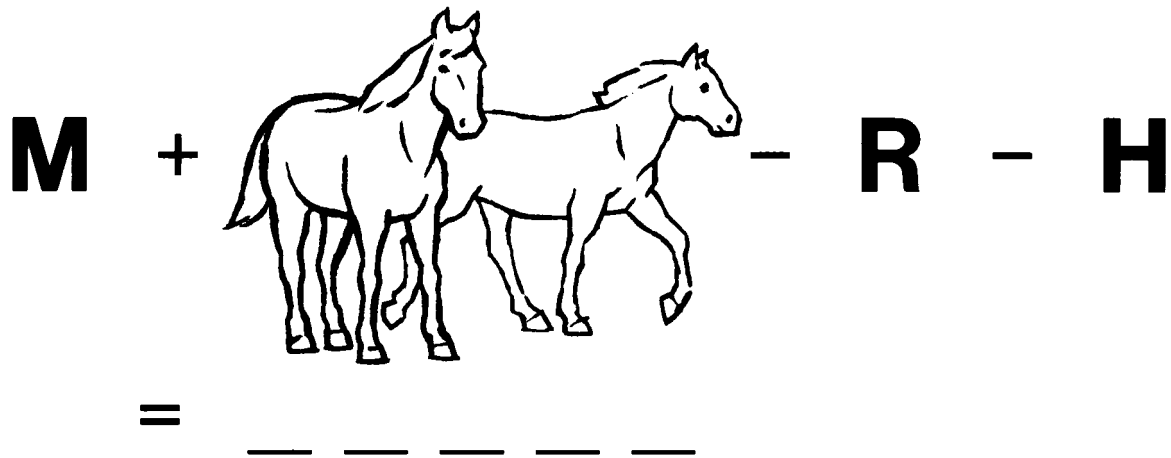



**BIBLE MEMORY** Psalm 23:1-6

### ISRAEL IN EGYPT

Find out who our next lesson is about by drawing a line through the letters: X, Y and Z. Then write the rest of the letters on the lines below.

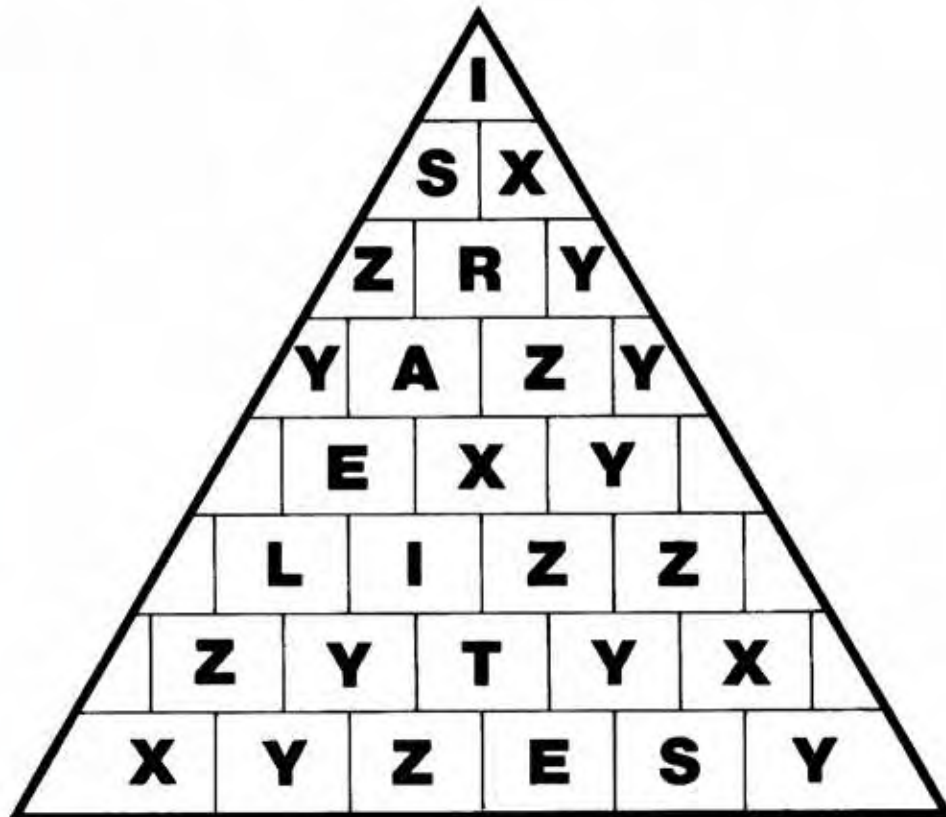

-----

---

# YOUTH

---

LEVEL 2

---

# BIBLE

---

# LESSONS LESSON 11

---



God Sends Plagues Upon Egypt

---

---

# GOD SENDS PLAGUES UPON EGYPT

---

**P**haraoh, king of Egypt, was angered after Moses and Aaron had left the palace. He gave orders to his taskmasters to make the Israelites work harder than before. Only this time the Israelites had to gather their own straw to make bricks. This made them very unhappy.

After this, God again told Moses and Aaron to go and see Pharaoh. "Now you will see what I will do to Pharaoh," God said to Moses. "After I have brought many plagues upon Pharaoh and his people, they will let you leave Egypt."

Moses and Aaron then went to see Pharaoh. This time Pharaoh wanted to see a sign of God's power. So Aaron threw his rod to the floor and it became a large, wiggling snake. Pharaoh's **magicians** also threw their rods to the floor and they became snakes. However, Pharaoh and his magicians were surprised when the snake from Aaron's rod began eating up all the other snakes.

Pharaoh was angered by this and would not let the Israelites leave Egypt.

The next morning, Moses and Aaron went to the river

---

Parents: Explain the meaning of the boldface words.

---



where Pharaoh was taking a bath. God had told Moses and Aaron the night before to again ask Pharaoh to free the Israelites.

"Our God has sent us to ask you to free the Israelites," they said to Pharaoh. "If you do not, God will turn your waters into blood."

"I will not free your people!" Pharaoh scoffed at Moses. "Let us see if your God can turn the waters into blood."

Aaron then raised his rod high above his head and brought it quickly down into the water. Suddenly the water began to change color. It began to turn red. Soon all the water in the rivers, streams and ponds of Egypt became blood.

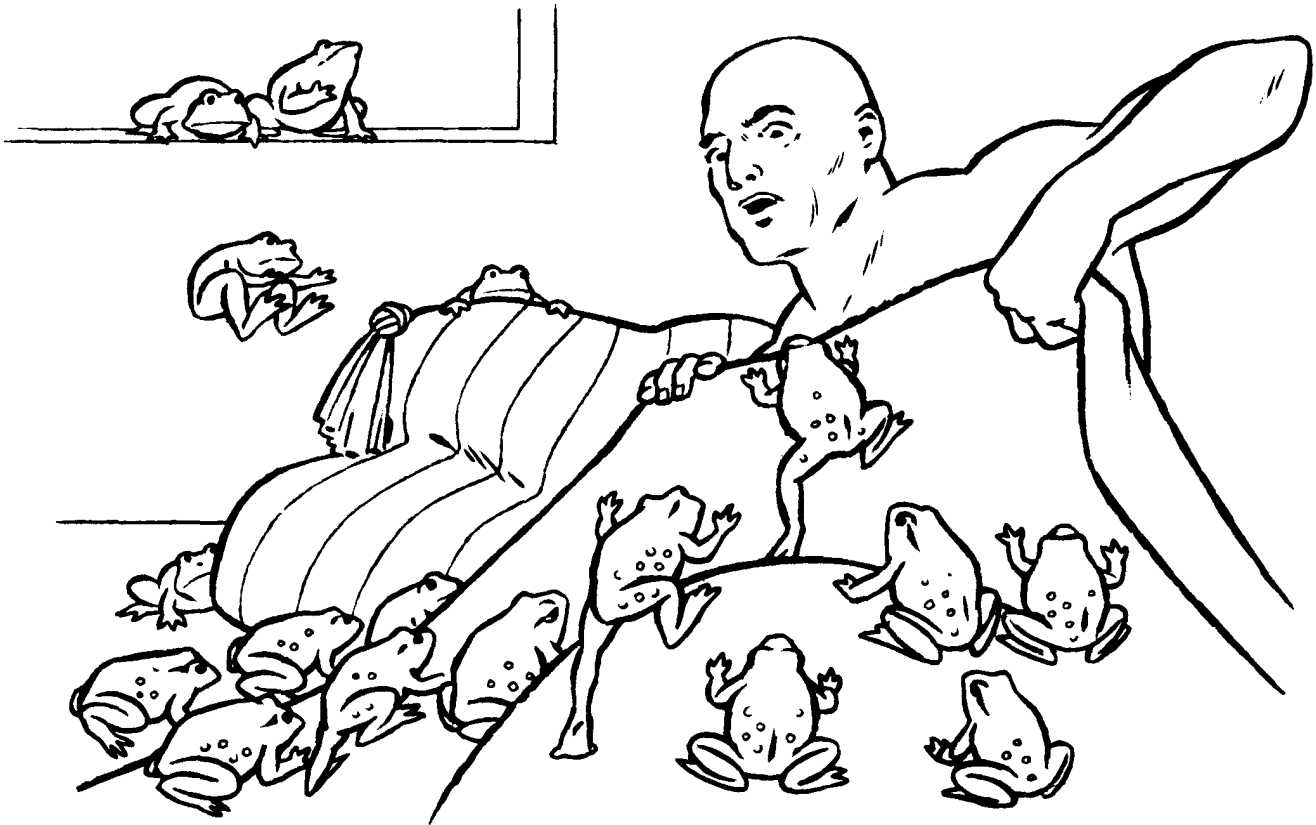

At the end of seven days, Moses and Aaron went to see Pharaoh. By now the people of Egypt had suffered greatly from the lack of fresh water.

Moses and Aaron asked Pharaoh to free the Israelites. But Pharaoh would not let them go.

Now God sent a plague of frogs from out of the waters of Egypt. Once again Aaron held his rod out over the waters as God had commanded. When he did, **millions** of frogs began coming from the river. They also came from the streams and ponds. They were all over the land of Egypt. Pharaoh was surprised to awake the next morning and find frogs in his bed.

Pharaoh called for Moses and Aaron to quickly come to the palace. He asked them to stop the plague of frogs and he would let the Israelites go. But when the plague had ended, Pharaoh would not free the Israelites.



God would now show Pharaoh more of his power. God commanded Moses and Aaron to strike the ground with the rod. "Tell Aaron to strike the ground with his rod," God said to Moses. "The dust will then become lice all over the land of Egypt."

When Aaron hit the ground, the dust became lice. Soon, all the Egyptians and their animals were itching from the lice. Still, Pharaoh would not free the Israelites from slavery in Egypt.

---



Because Pharaoh again **refused** to let the people go, God sent a fourth plague. This time God sent **swarms** of biting flies.

God also performed another miracle. He did not allow the flies to come near the land of Goshen. That is where the Israelites lived.

Pharaoh again asked Moses to stop the plague and promised to free the Israelites. "Ask your God to take away the flies," Pharaoh pleaded. "I will let your people go to sacrifice in the wilderness. Only do not go very far."

So Moses prayed to God and God took away the flies. And, when the flies were gone, Pharaoh changed his mind and would not free the Israelites.

---

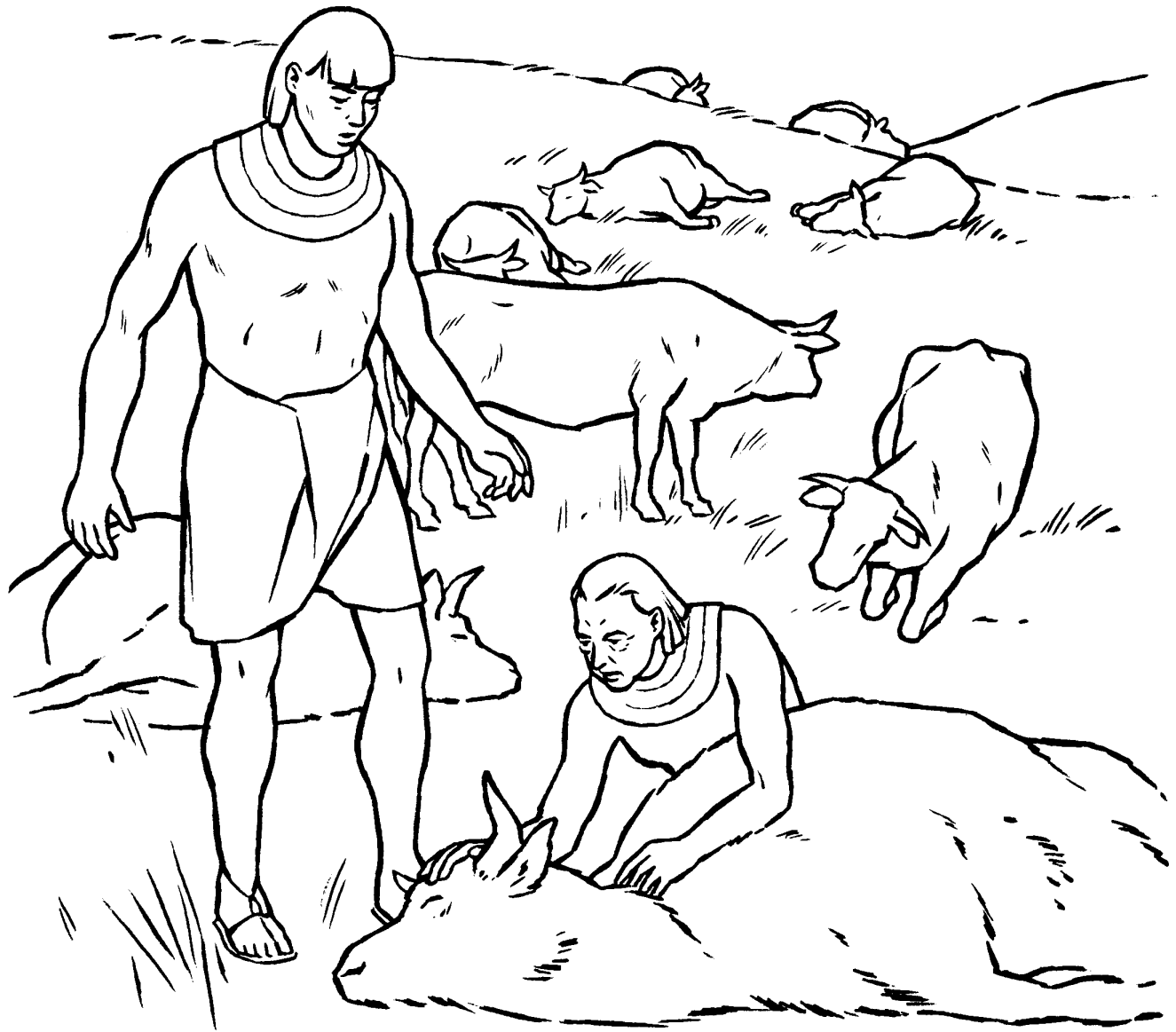

Moses and Aaron then warned Pharaoh and the Egyptians that many of the animals in Egypt would die of **disease** the next day. Moses and Aaron also said that none of the Israelites' animals would be hurt.

The next day, many of the Egyptians' cattle, camels, sheep and other animals died. But all the Israelites' animals in Goshen were safe.

Pharaoh was angry because many of the animals had died, and would not let the Israelites go.

---





As Moses and Aaron stood before Pharaoh, Moses threw handfuls of ashes from a furnace into the air. Later, as the ashes touched the Egyptians' skin, the Egyptians broke out in painful boils. Many of the Egyptians could not walk or stand because of them.

But even these painful boils were not enough to make Pharaoh give in to the God of Israel and let His people go free to worship Him.

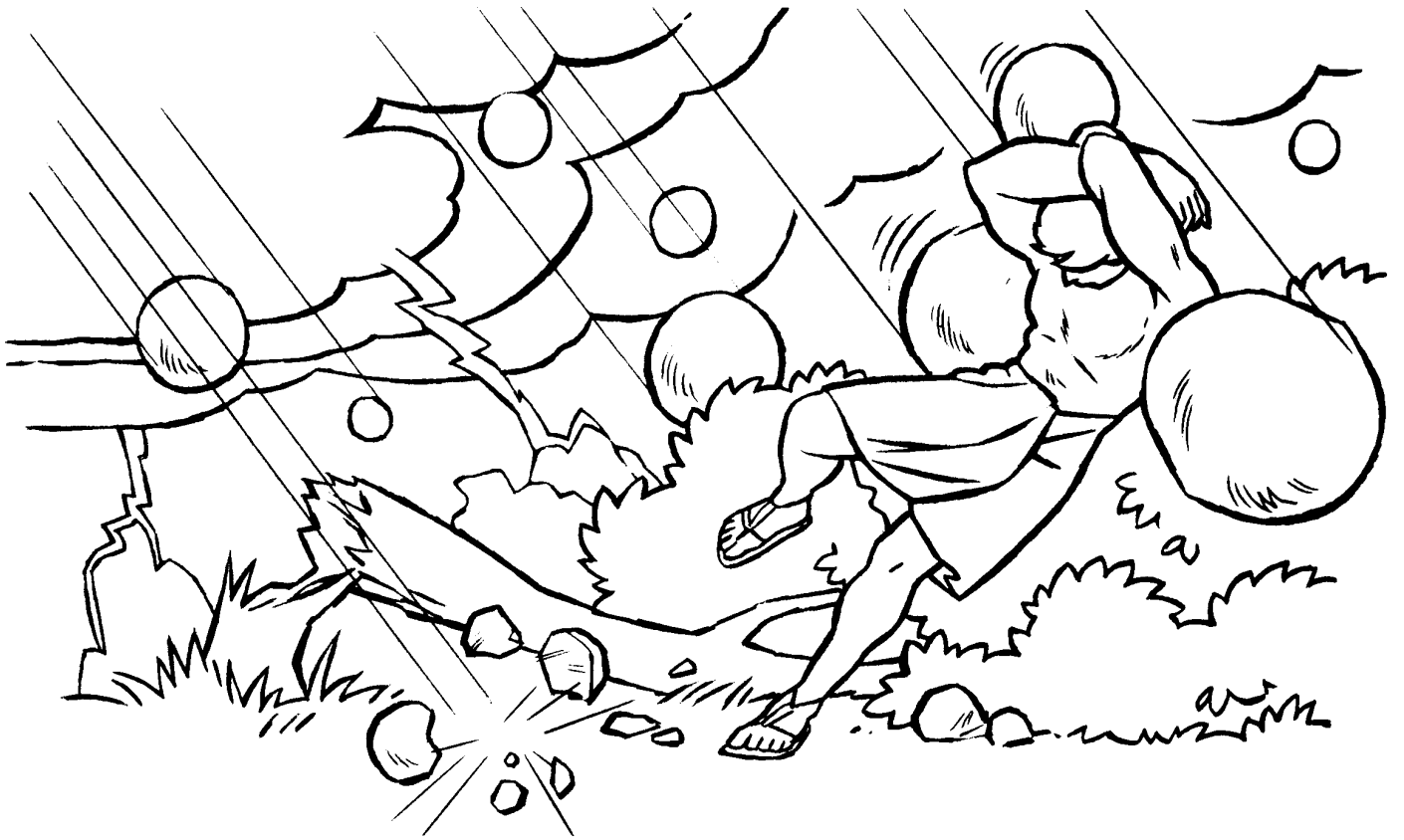

Pharaoh and his magicians were still healing from their boils when the warning of the next plague came. "About this time tomorrow," Moses said, "there will be a terrible hailstorm and lightning!

"Bring your cattle and other animals into shelter or they will be killed," Moses continued.

Some of the Egyptians believed Moses and Aaron and stayed inside. All of those who did not listen to the warning were killed. Many of the **crops** were also smashed by the large **hailstones** that fell from the sky. But in the land of Goshen the Israelites were safe from the storm.

"Ask your God to stop this storm," Pharaoh pleaded with Moses. "I will let your people go." Moses then went outside the city and asked God to stop the storm and God caused the storm to end. Afterwards, Pharaoh again changed his mind.



Not much remained of the trees and crops after the hailstorm. Only the tiny roots of flax and barley which were still in the ground were safe. But since Pharaoh again refused to let the people go, God sent locusts to eat what little remained. The locusts ate all of the green plants, flowers and fruit trees in the land of Egypt.

Pharaoh hurriedly ordered his servants to bring **Moses** and Aaron to the palace. When they arrived, Pharaoh ran up to meet them. "I have been wrong!" Pharaoh exclaimed. "Please ask your God to take away the locusts."

Moses asked God to remove the locusts from the land, and God caused a strong wind to blow them into the Red Sea.

Now that the locusts were gone, Pharaoh would not free the Israelites.



Moses and Aaron knew that much more would be needed before Pharaoh would let the Israelites go. Now God instructed Moses and Aaron to hold the rod toward the sky. As Aaron held his rod over his head, the sky started to become dark. It became so dark that the Egyptians could not see to walk about. They could not see each other. Even lighted **torches** did not help. The darkness lasted for three days.

Pharaoh again asked Moses to take away the plague and promised to let the people go.

After the plague of darkness was gone, Pharaoh told Moses that he would not free the Israelites. He also told Moses that he did not want to see him again. So Moses and Aaron left the palace for the last time.

In our next lesson we will learn about the last plague God sent on Egypt and what happened to the Israelites as they journeyed to Mount Sinai.

**BIBLE MEMORY** Exodus 20:1-7

### NUMBER THE PLAGUES

In the circles below each picture,  
fill in the correct number showing the order  
in which God sent the plagues on Egypt.



# YOUTH

LEVEL 2

# BIBLE

# LESSONS

SPECIAL FEAST  
LESSON

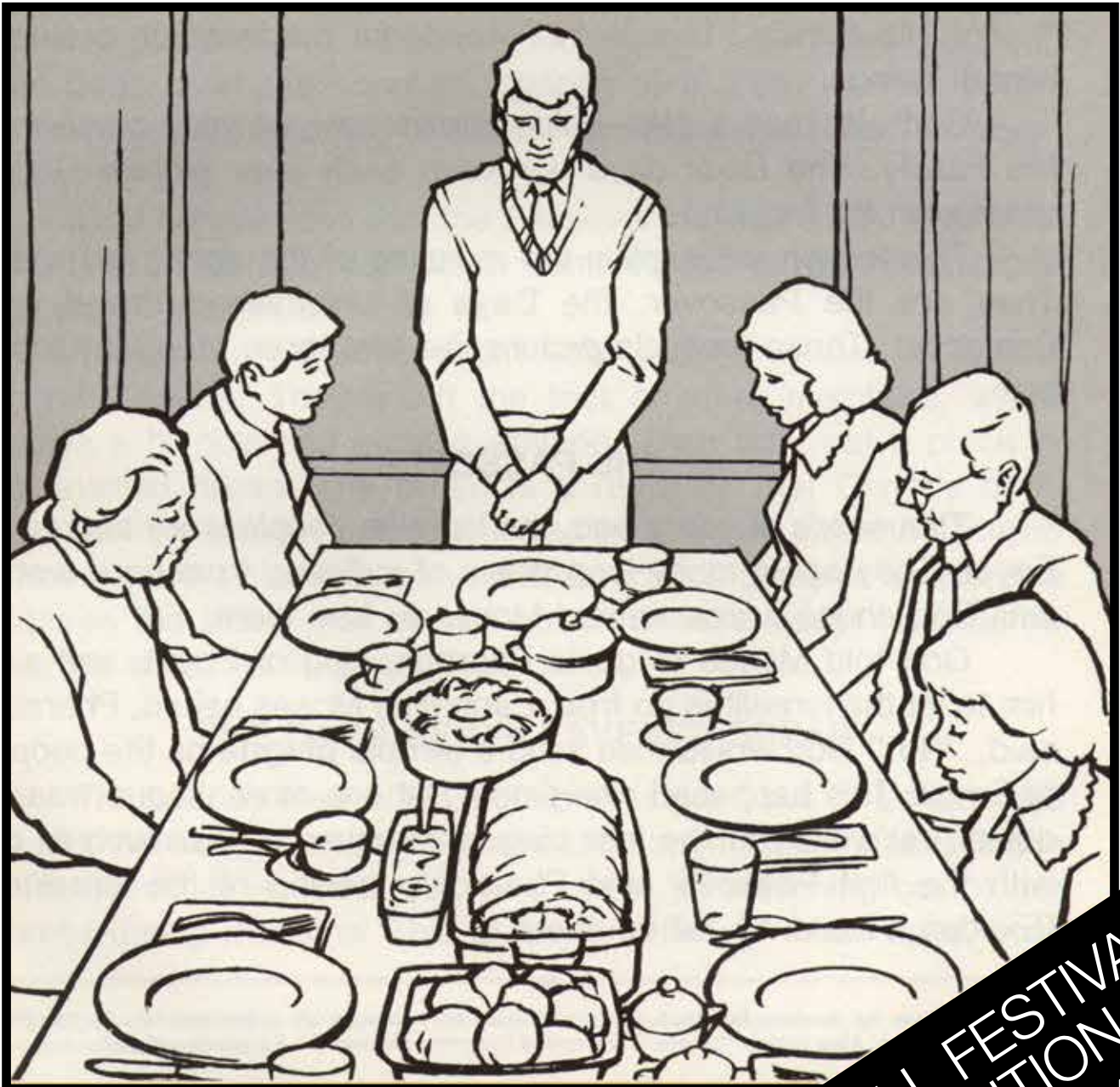

The Fall Feasts

FALL FESTIVAL  
EDITION

---

# THE SPRING FEASTS

---

**G**od wants everyone who has ever lived to become members of His Family. This is His wonderful purpose for creating human beings.

God also has a plan which shows how we may come into His Family. The feast days we keep each year picture God's great plan for mankind.

This lesson will explain the meaning of the spring festivals. They are the Passover, the Days of Unleavened Bread and Pentecost. These festivals picture the first three steps in God's plan.

## THE PASSOVER

Thousands of years ago, the Israelite people were **slaves** in Egypt. They spent many long years of suffering from hard work, until God chose a man named Moses to free them.

God told Moses to go to Pharaoh, king of Egypt, and ask him to let the Israelites go free. Each time Moses asked, Pharaoh said, "No!" God would then send a terrible **plague** on the people of Egypt. This happened nine times. But one more plague was to come. Let's look at the last plague, because it has much to do with the first Passover and Pharaoh's freeing of the Israelites (Exodus 11 and 12 tell us about it).

---

Parents: Explain the words in **boldface**. Explain "slaves" so your child will understand why the Israelites wanted to be free. Also explain "plague," and review the other plagues the Egyptians suffered.

---

Illustrations by Greg Sandilands, Ken Tunell and Michael Woodruff

---

The tenth and last plague God sent was the death of the firstborn in the land of Egypt. This included the death of the firstborn animals as well as the people. If you are the oldest child in your family, you are the firstborn.

God told the Israelites that on the night of the Passover they were to roast a healthy male lamb and eat it with their families. They were to eat it with unleavened bread and bitter herbs. They were told to take some of the blood of the lamb and smear it on the doorposts of their houses. God's angel would see the blood and **pass over** their houses, sparing their firstborn from death. Then they were also told to eat flat or unleavened bread for seven days.

God commanded that the Passover be kept every year from that time forward. When Christ came to this earth, He changed the way it was to be kept.

Today, on Passover night your parents attend a special church service. They wash the feet of other members, which shows a humble and serving attitude. Then they eat a piece of unleavened bread. The bread is a reminder that Christ's body was horribly beaten before He died so that we could be healed when we are sick. Your parents then drink a glass of wine which pictures the blood that poured out of Christ's body. He died so that we could be forgiven of our sins.

## **THE DAYS OF UNLEAVENED BREAD**

The second festival in God's plan is the Days of Unleavened Bread. We keep this feast by not eating anything with leavening in it for seven days. God tells us to have all leavening out of our homes during this time. This is why just before these days, your

---

Parents: Explain what you do on Passover night. Be sure to include the significance of the foot washing, unleavened bread and wine.

---



---

mother cleans the cupboards and pantry and throws out all the crackers, cookies, and any other foods which contain leavening.

The lesson God wants to teach us by this festival is to put sin or wrong-doing out of our lives just as we put out the leavening. Remember that leaven puffs things up just as sin puffs us up.

For this reason, God wants us to put away sin or doing wrong before it spreads to other areas of our lives. God wants us to keep His Commandments. Eating unleavened bread for seven days reminds us of this lesson and our need to obey Him. This year as you help your mother put out this leavening, remember the lesson God wants us to learn from this festival.

## **PENTECOST**

Let's now take a look at the third festival picturing the third step in God's plan. It is called Pentecost, and means "fiftieth (day)." Pentecost is fifty days from (beginning with) the Sunday after the Sabbath which usually comes during the Days of Unleavened Bread. Another name for Pentecost is the "Feast of Firstfruits." Pentecost pictures the Church today and how it fits into God's plan.

Many years ago, Jesus Christ came to earth and died on Passover day. He was then resurrected, or made alive, after being dead three days and three nights. He then went to heaven to appear before God the Father. Fifty days later, God sent the Holy Spirit to Christ's disciples on the Day of Pentecost.

The Holy Spirit is a special spiritual help which God gives to those who have been baptized. Before you receive the Holy

---

Parents: Explain more about God's way of "give," contrasting it with Satan's way of "get." Tell your child the importance of sharing his or her toys so others, too, can receive enjoyment. Explain why it is important to have a serving attitude.

---

---

Spirit, you only have the “spirit in man” which makes you very different from the animals because it makes it possible for you to think and reason. Because you are children of baptized parents, you have the Holy Spirit working **with** you, but when you are baptized (when you are grown up) you will have the Holy Spirit **in** your mind to help you do what is right.

The Day of Pentecost shows us that the people in God’s Church who have received His Holy Spirit are the “firstfruits” of all those to be called by God to understand His ways and be born into His Family. The “firstfruits” are the ones who will help Christ teach God’s way of life to the rest of mankind in the World Tomorrow. Since no human but Christ has yet been given eternal life, Christ is the **first** of the firstfruits to be born into the Family of God.

The people in God’s Church are the first to be given the opportunity to become members of God’s Family. Later, when Christ returns to earth and sets up His ruling Kingdom, the entire world will be given the opportunity. This includes all those who have lived and died, but have never heard or understood this wonderful truth of God!

The festivals of the Passover, Unleavened Bread, and Pentecost teach us the first three steps in God’s plan for mankind. In the special Fall Festival Lesson, you will learn the meaning of the last four steps in God’s plan, as pictured by the four feasts which come in the fall.

---

Parents: Explain how the Holy Spirit that is with your children can be a benefit if they ask God for help.

---

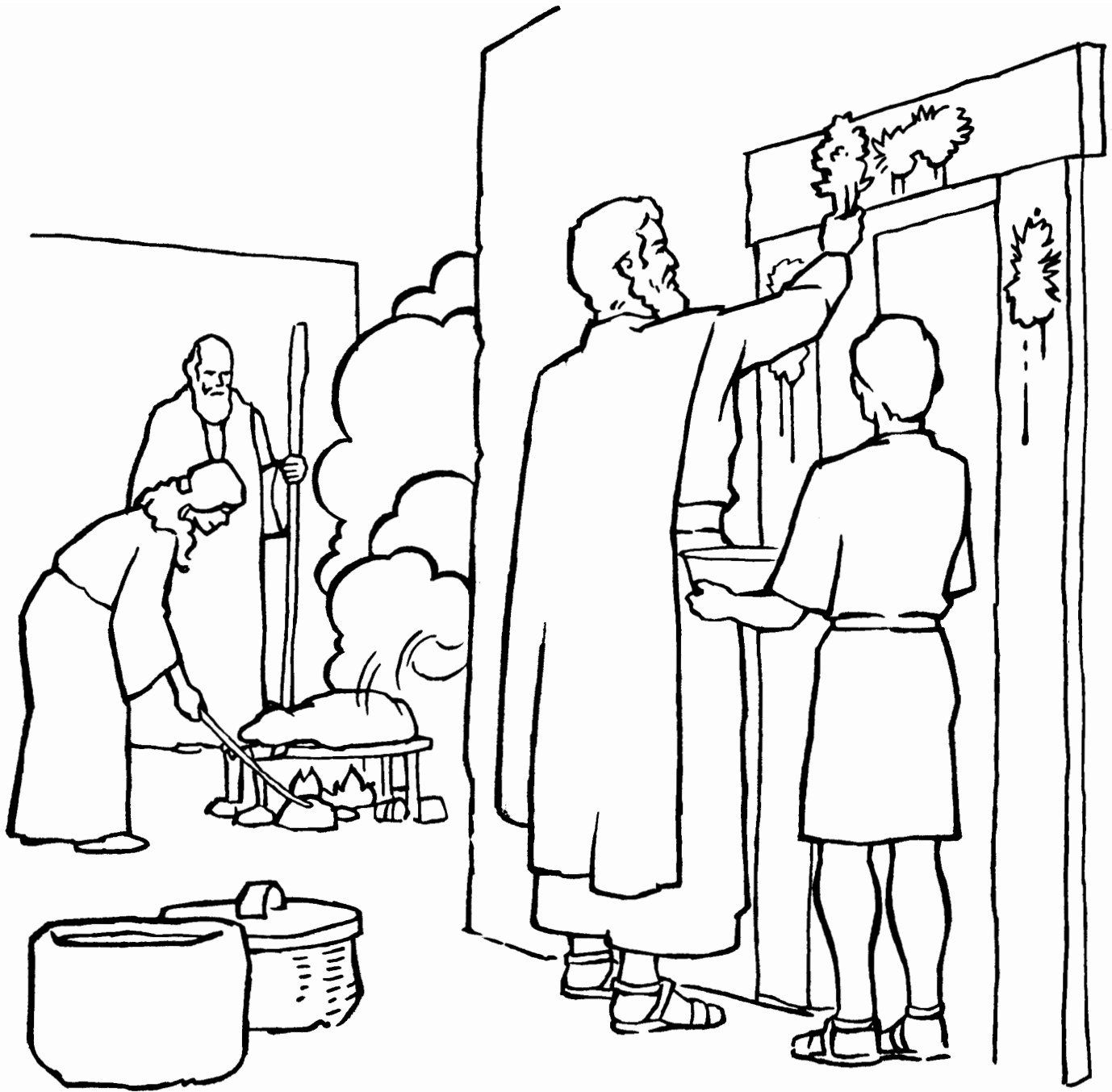

The Israelite fathers prepared a lamb for the Passover. They smeared blood on their doorposts, so the death angel would **pass over** and not kill their firstborn.

---

Parents: Explain to your child that just as God protected the Israelites who obeyed Him that first Passover, God also protects His people who obey Him today.

---



Today, these are the things God's people do on Passover night to remember Christ's death.

---

Parents: Instruct your child to color the pictures. Also, review the meaning of Passover, and the meaning of each of the pictures.

---



The Israelites were very happy that God had delivered them from slavery in Egypt! This night began the Days of Unleavened Bread.

---

Parents: Ask your child these questions: What did the Israelites celebrate on the night they left Egypt, that God's people celebrate today? Why did they make their bread without leavening? What does leavening do to bread? What does leavening have to do with sin?

---

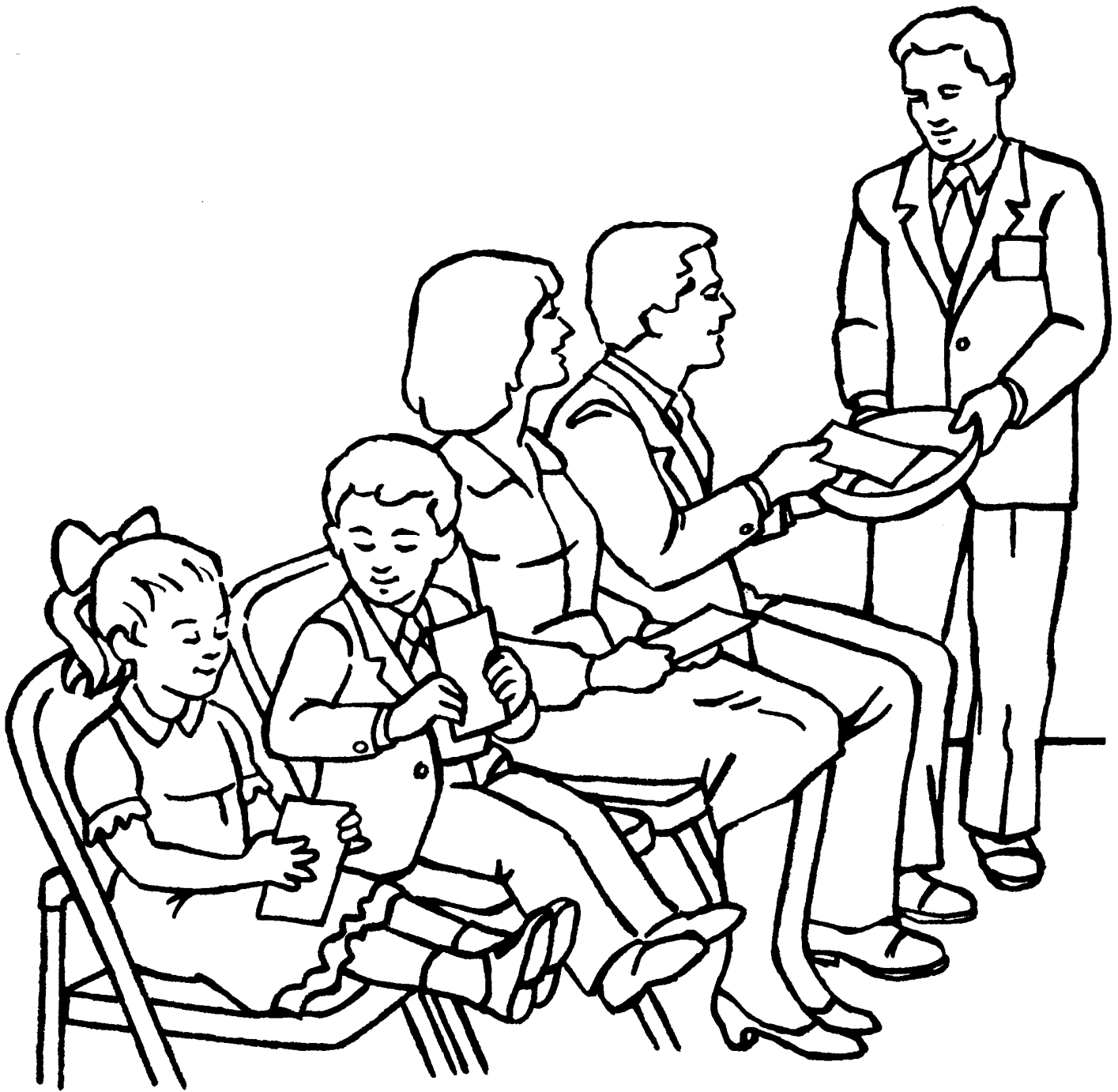

Pentecost pictures God's people as the "first-fruits" of those He is calling into His Family.

---

Parents: Explain to your child that he or she will help teach God's way of life — the way of "give" — in the World Tomorrow.

---

---

## COLOR BY NUMBER

Color the foods below by number, using the color key at the bottom of the page. Then circle the foods you may eat during the Days of Unleavened Bread.

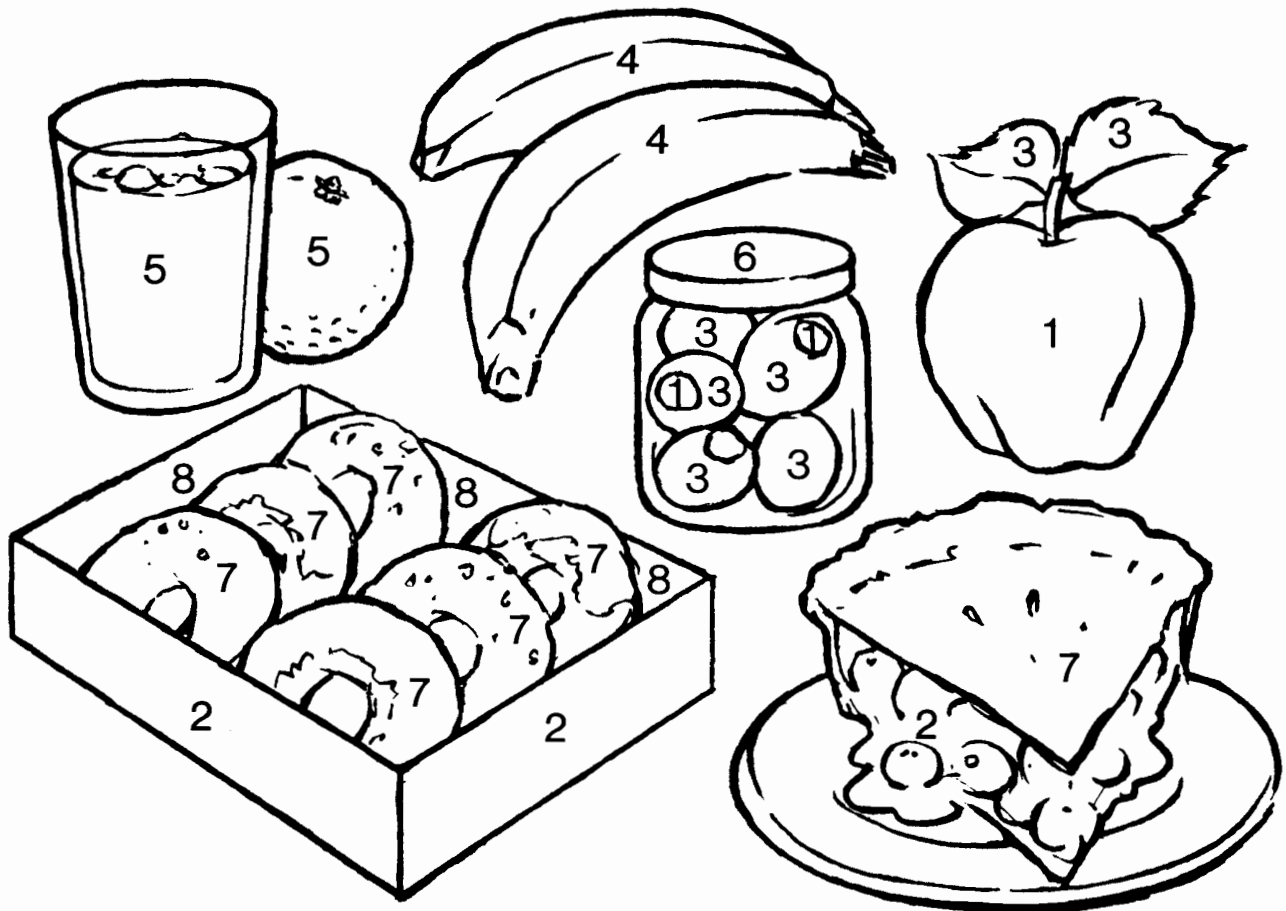

### COLOR KEY

1—Red      2—Blue      3—Green      4—Yellow  
5—Orange   6—Purple   7—Brown   8—Black

---

---

# MY SCRAPBOOK

---

Parents: Your child may wish to paste photographs of the Night to Be Much Observed here.

---



## MYSTERY CODE

Match the numbered blank spaces with the code at the bottom of the page to find out how the children of Israel went out of Egypt on the night of the first Day of Unleavened Bread—the Night be Much Observed (Exodus 14:8).

“

20 8 5                      3 8 9 12 4 18 5 14                      15 6

9 19 18 1 5 12                      23 5 14 20                      15 21 20

23 9 20 8                      1 14                      8 9 7 8                      8 1 14 4

”

A	B	C	D	E	F	G	H	I	J	K	L	M
1	2	3	4	5	6	7	8	9	10	11	12	13
N	O	P	Q	R	S	T	U	V	W	X	Y	Z
14	15	16	17	18	19	20	21	22	23	24	25	26

YOUTH

LEVEL 2

BIBLE

LESSONS SPECIAL FEAST  
LESSON



The Spring Feasts

SPRING FESTIVAL  
EDITION

NAME \_\_\_\_\_

FEAST  
SITE \_\_\_\_\_

MOTEL \_\_\_\_\_

PLEASE RETURN IF FOUND

# THE FEAST OF TRUMPETS

The Feast of Trumpets is one of God's festivals. It is also a Holy Day. Each festival shows us a picture of something that has already happened or will happen soon. The Feast of Trumpets shows us the time when Jesus Christ will come back to the earth. The very loud sound of a trumpet will tell the whole world that this is happening.

Many terrible things will be going on all over the earth just before Jesus returns. People will be going to war and killing each other. Millions of people will be starving. Other millions will be very sick. Christ will have to come back to the earth to stop all of these bad things. Christ wants to make things good again on the earth, but first Satan must be taken away so he won't be able to cause people to want to do bad things. The next festival will tell us more about Satan being taken away.

When God's people hear the sound of the trumpet, they will be in a place of safety. God has promised to take his obedient people to a place of safety to protect them from the great destruction in the countries of the world. If you obey your parents, God will be sure you are safe with them.

Don't forget to check your piggy bank to see if you've saved some money for the offering on the Feast of Trumpets. This is one of the few times God tells us to give money in church to help do God's Work.

---

Parents: Read the above story to your child. Explain that a trumpet is often used to announce that something important is coming or is going to happen. Examples: reveille, raising the flag, sound of alarm for war in the Bible.

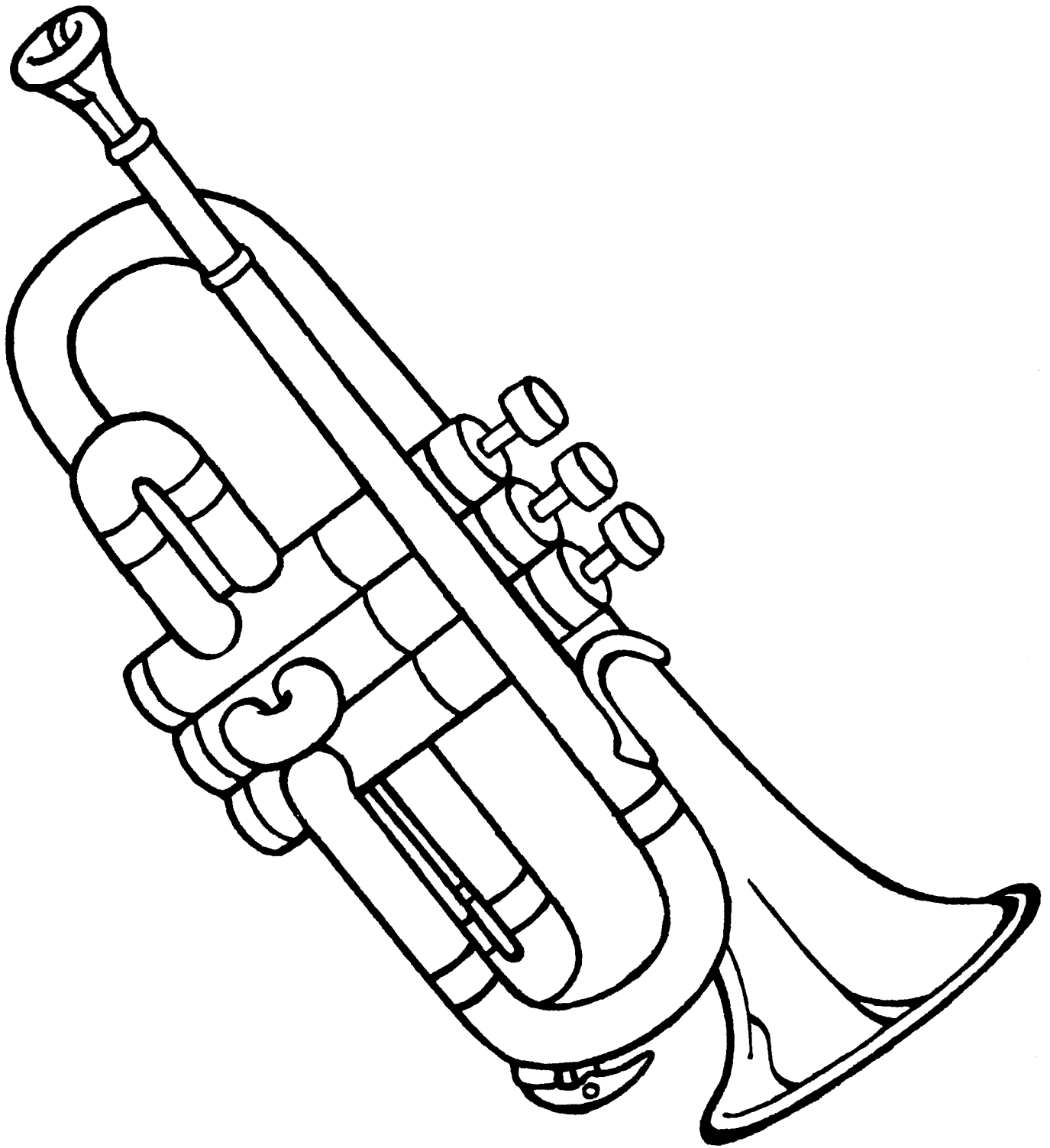

Color the trumpet.

---

Parents: Ask your child questions like these:  
What sound does a trumpet make?  
Does it make a loud, clear sound?  
Why will God use a trumpet to tell everyone Christ is coming?

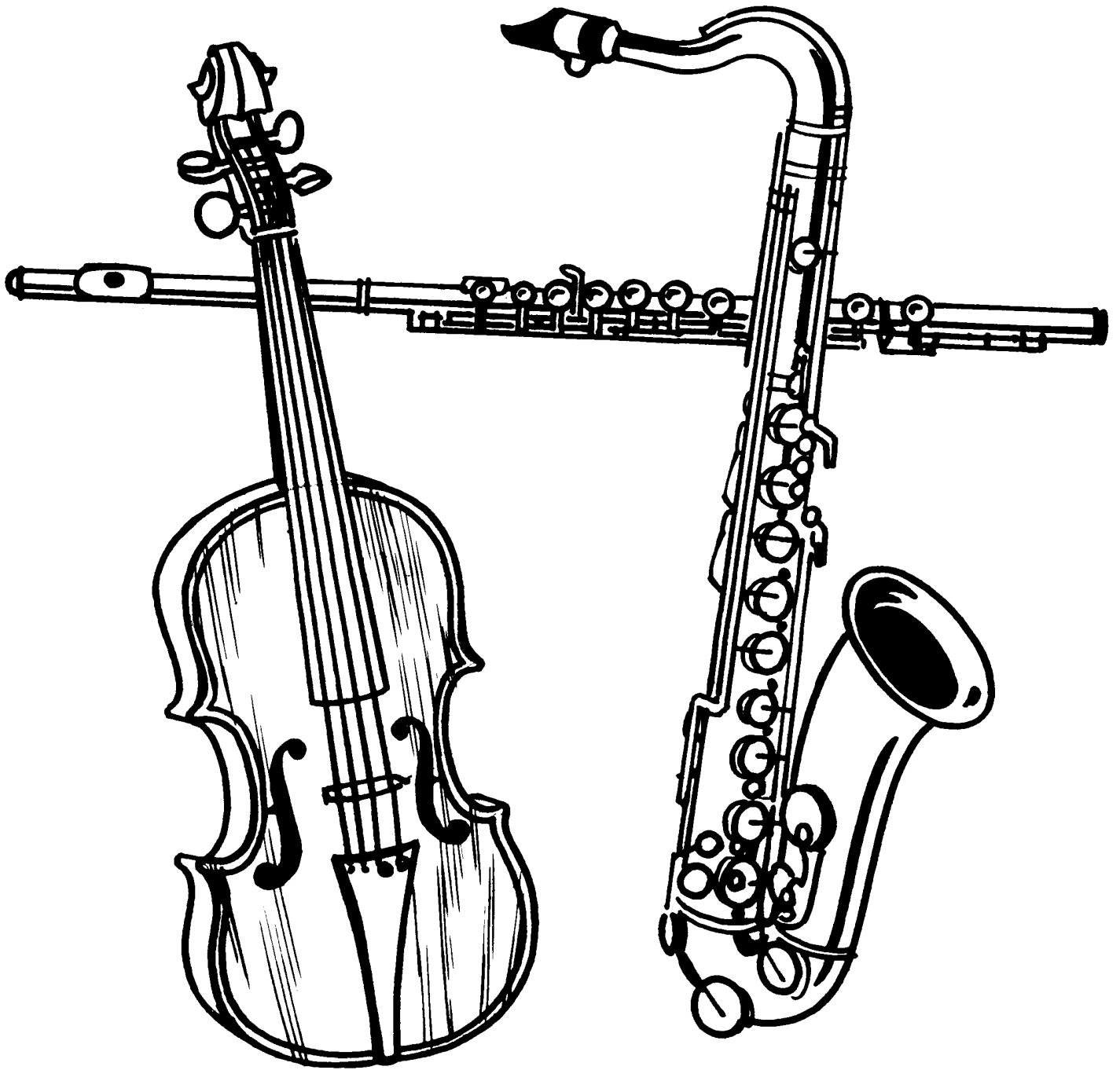

Color the instruments.

---

Parents: Ask your child questions like these:  
What kind of sound do these instruments make?  
Why is the trumpet better than these instruments to tell many people something important is going to happen?

# THE DAY OF ATONEMENT

The Day of Atonement is another one of God's Holy Days. It shows a time to come when people will be at one with God. Satan will no longer be able to cause people to think about doing wrong any more. People will want to do good and be close to God.

Satan will be chained in a prison for 1,000 years. This will happen when Jesus returns to the earth. With Satan not around, Christ can begin to make all things good again. Everyone will begin to obey God and keep His feasts. The next festival tells us about that wonderful time. But before we go on, let's see how God tells us to keep the Day of Atonement today. God tells us to fast on this day. This means we are not to eat or drink anything that day. This is also one of the times when God tells us to give an offering in church.

---

Parents: Read the story to your child. Explain that by fasting we can draw closer to God. This helps picture the time when Satan will be put away and all mankind will be close to God.

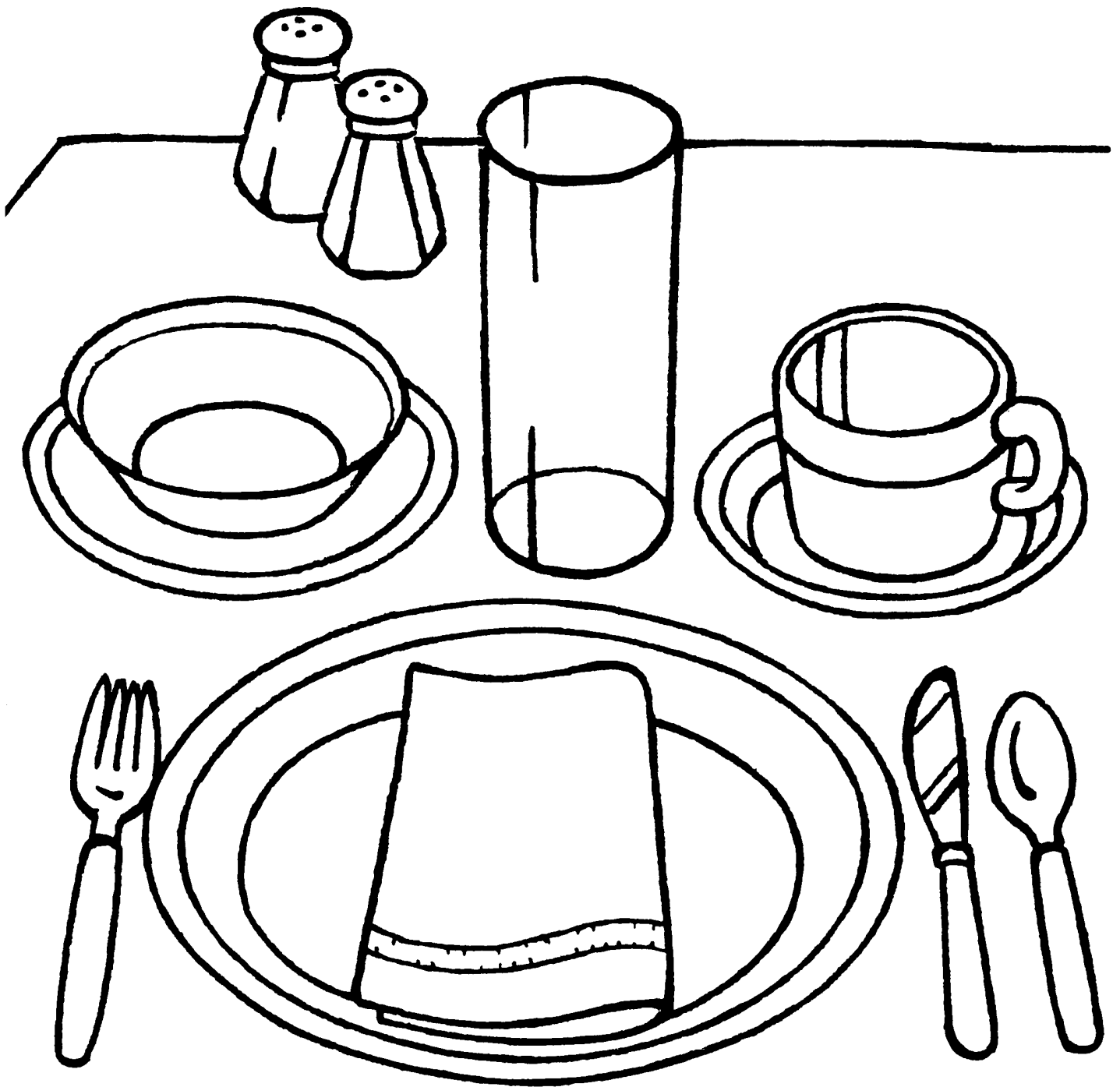

We don't eat or drink on the Day of Atonement for a special reason. Color the picture of the empty plate and glass.



# THE FEAST OF TABERNACLES

The Feast of Tabernacles is another one of God's festivals. It shows the time when Jesus Christ will be King over all the earth. This time is called the Millennium, because it will last 1,000 years. Satan will not be around then, so everyone will be obeying God, living by His laws, and keeping His feasts.

During the Millennium you and your friends in church will have a chance to be great leaders of the earth under Christ. During this happy world tomorrow, those who are blind will see, the deaf will hear, and those who are crippled will walk and run. People will be healed of all these things.

The animals during the Millennium will all be tame and gentle. Lions will no longer kill other animals for food. They will eat straw like cows. Children will be able to play with lion cubs. Even snakes will not be harmful. These are wonderful things to look forward to.

The way God tells us to keep the Feast of Tabernacles today is by going away from our homes to a place where God's Feast is held and by living in a motel or hotel, camper or camping in a tent. God makes sure we will be able to have enough money to go by telling us to save our second tithe. Every time you get a dollar, one dime of

that should be saved for second tithe to spend at the Feast of Tabernacles. Each time your father or mother gets a paycheck, they put one tenth of the money into a bank to save as second tithe so you and your family can go to the Feast of Tabernacles.

This is a special feast because God wants us to be happy and do things together as a family so we can know how to teach many others to be happy after Jesus returns.

God tells us to give an offering on the Holy Day of the Feast of Tabernacles. Be sure to save some of your pennies, nickels, and quarters for that purpose.

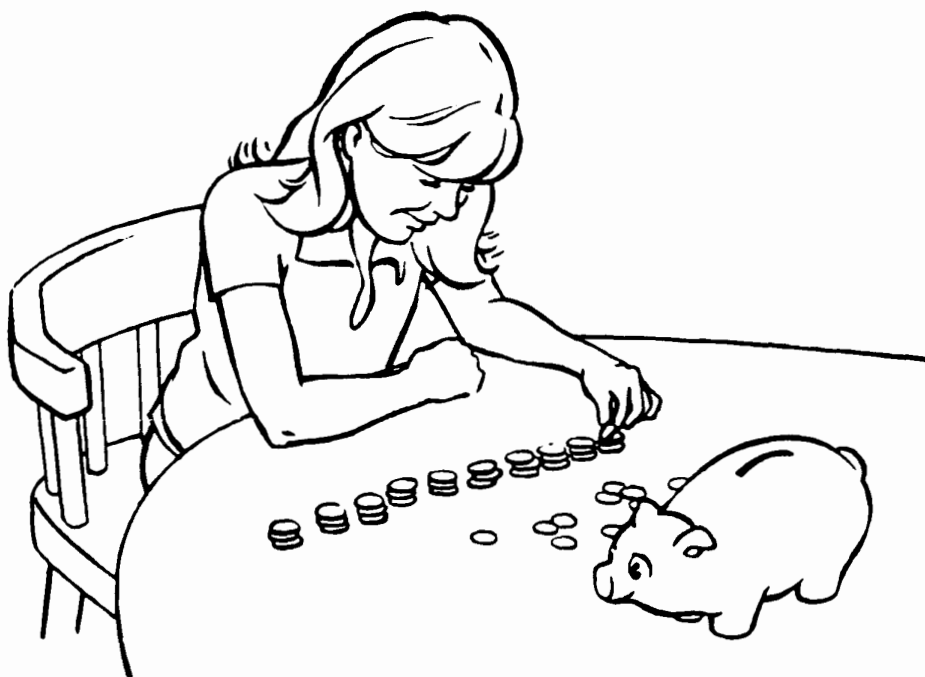

---

Parents: Read the story to your child. Explain that the word "tabernacles" means booths or temporary dwellings, which motels are. Explain that the Millennium hasn't come yet and it would be very dangerous to play with lions or snakes today. Explain further the law of tithing and how God blesses you for tithing and allows many unpleasant things to happen if you don't. Also, explain that offerings, in addition to tithes, are commanded by God to be given on the Holy Days. Remind them that "God loves a cheerful giver." (II Cor. 9:7).



**A child will not be hurt by a snake during the Millennium.**

---

Parents: Tell your child he won't have to be afraid of snakes when Christ returns.

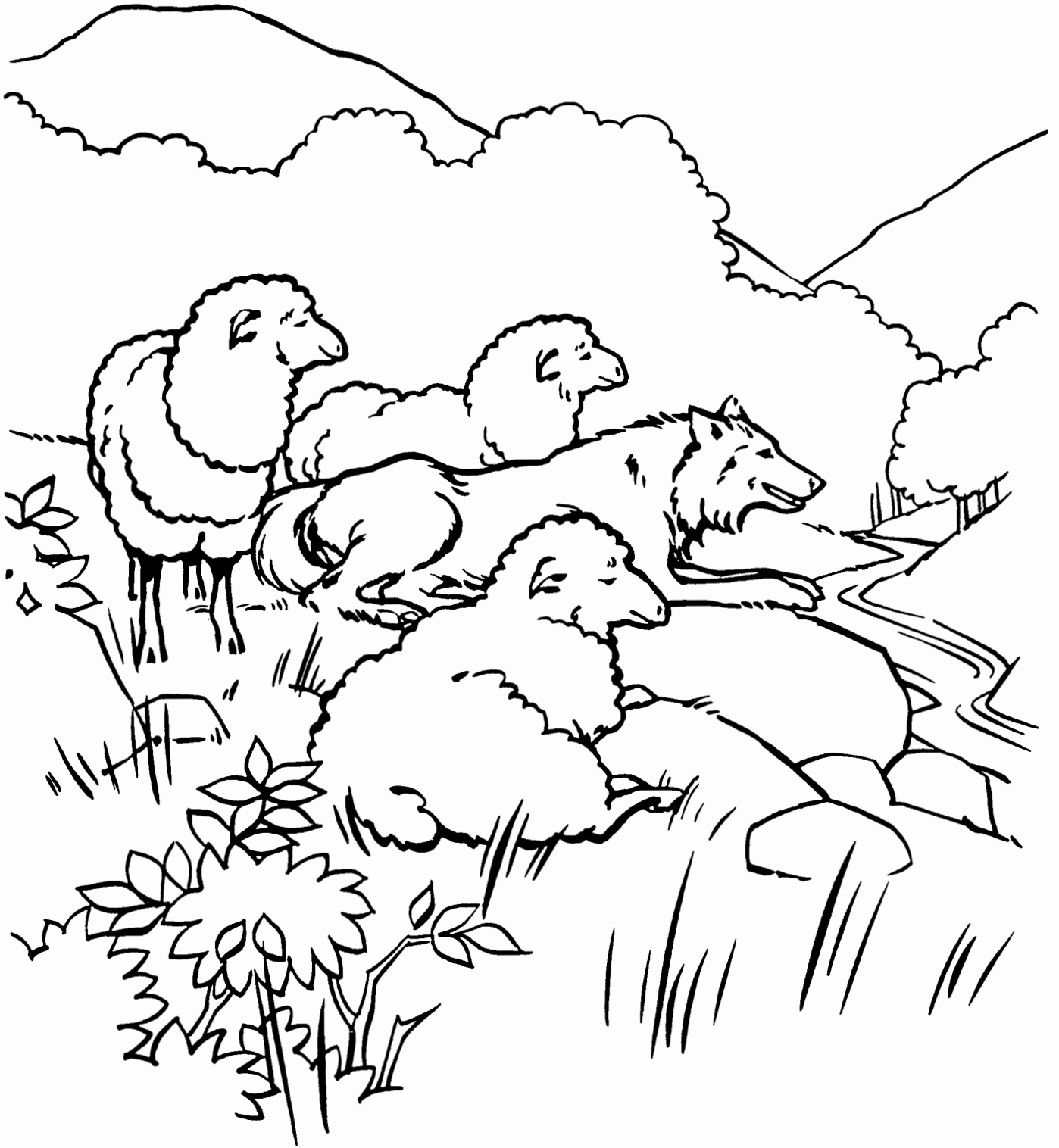

**A wolf will not want to kill lambs when Jesus rules the earth.**

---

Parents: Explain that the wolf would kill the lamb today if they were together, but in the Millennium they will be at peace with each other.

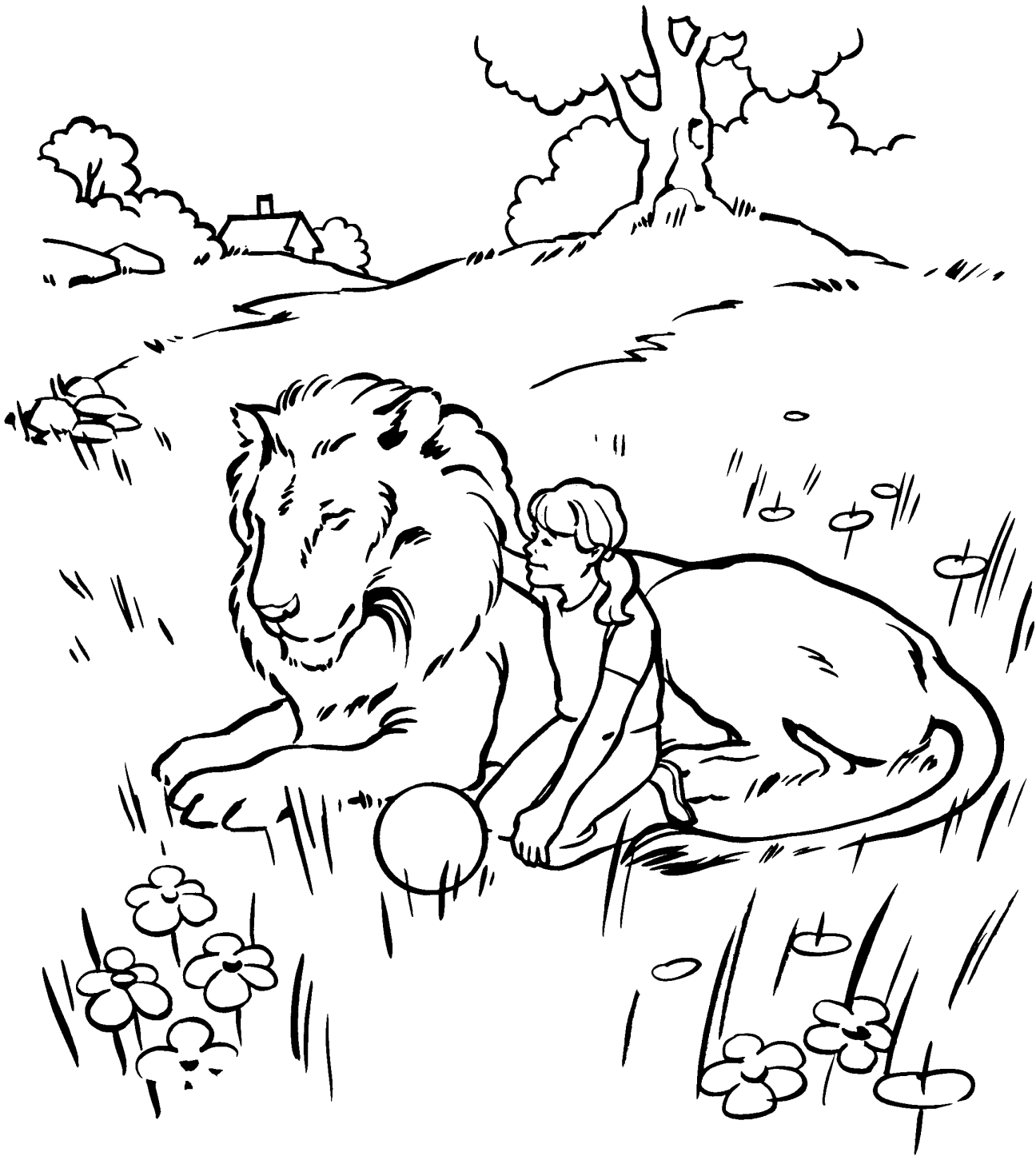

**A lion will not want to hurt a child during the world tomorrow.**

---

Parents: Explain that this would be dangerous now but in the Millennium it will not.



Can you help Mom remember all the things to pack for the Feast of Tabernacles?



Will everything fit?

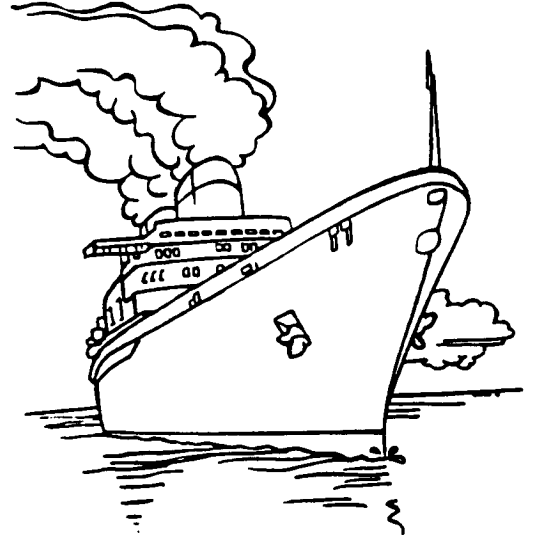
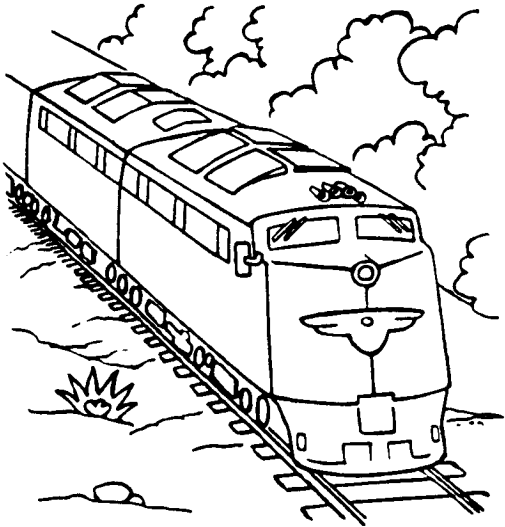
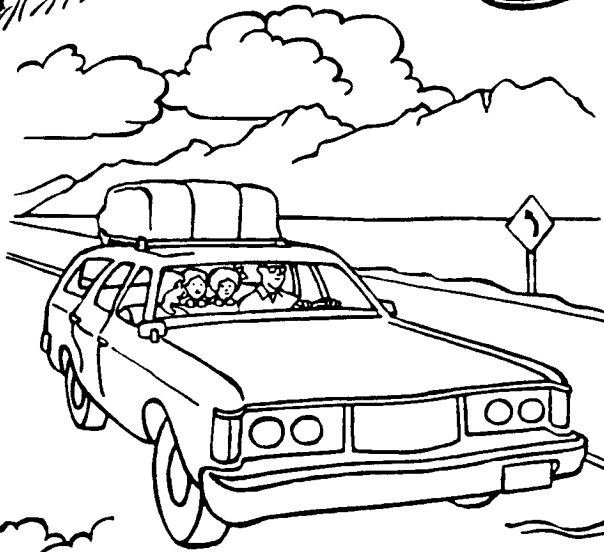

How did you come to the Feast?  
Circle one.



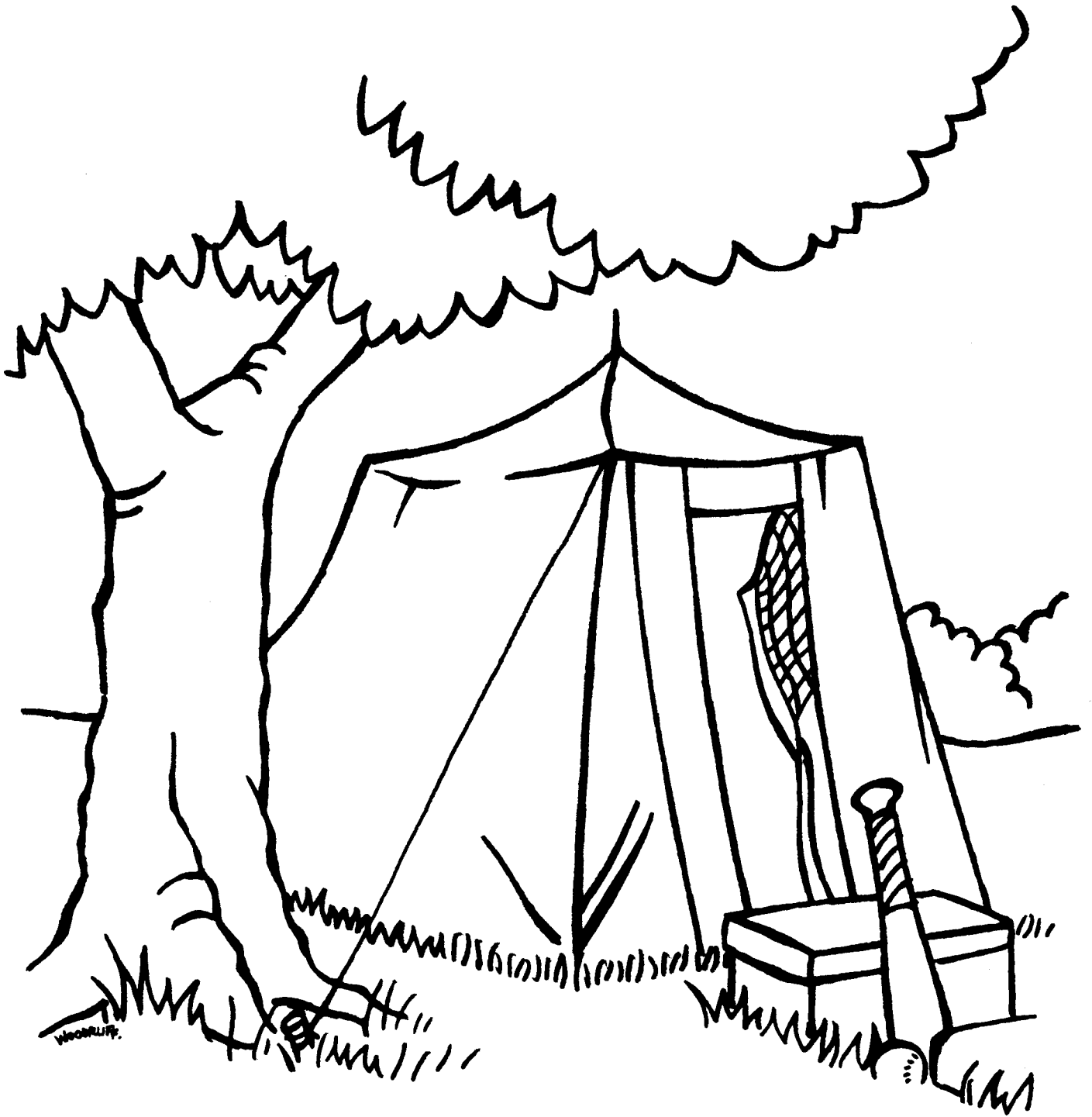

During the Feast, God tells us to live in temporary places. This usually means motels, tents or trailers or campers.



**During the Feast we must often eat our meals in restaurants.**



Have you saved for the offering?

# PROGRESS CHART

## Days of the Feast

	1	2	3	4	5	6	7	8
I did my part to keep our motel clean today.								
I said my prayers today.								
I made at least one new friend today.								
I was quiet in church today.								
I used good manners in the restaurants today.								
I was happy today.								

Here is a list of six things you should try to do each day of the Feast. At the end of each day place an "X" in the boxes of those things you did.

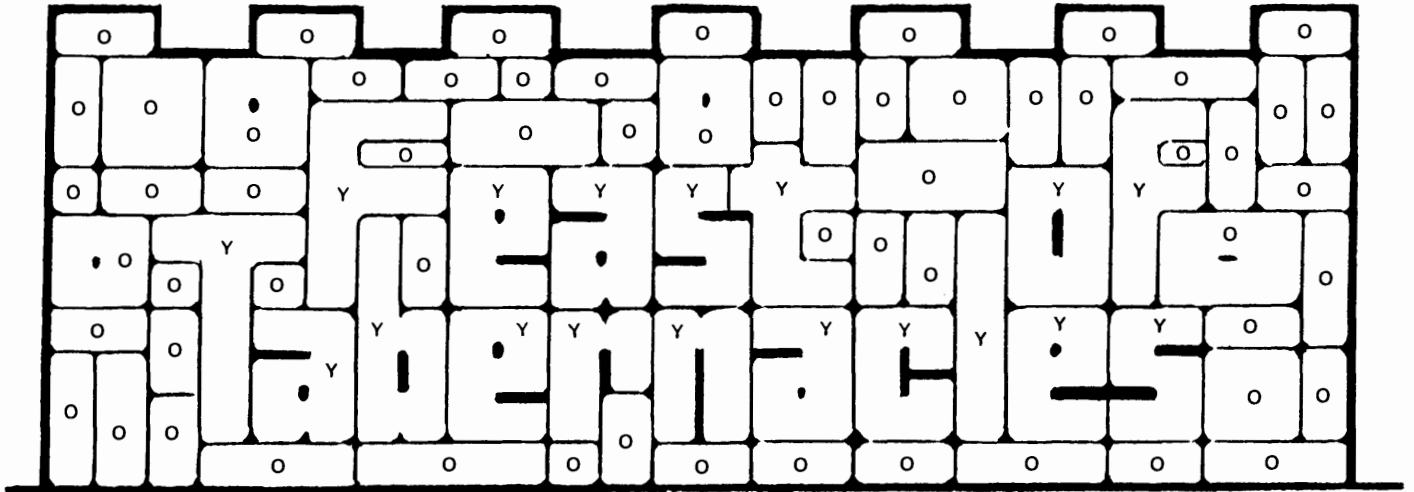

Color the stones in the temple wall to  
see where you are.

O= orange

Y= yellow

# FIND THE WORDS!

A	R	F	L	T	X	V	Y	A	C	M
T	A	B	E	R	N	A	C	L	E	S
O	F	O	N	E	X	T	N	P	O	L
N	T	W	G	D	L	R	E	T	S	P
E	N	H	R	L	A	G	S	G	K	R
M	I	F	E	A	S	T	Q	W	P	Y
E	O	P	A	U	T	L	M	E	I	A
N	J	A	T	Z	O	E	I	M	N	D
T	R	U	M	P	E	T	S	J	L	K

**TRUMPETS**

**ATONEMENT**

**FEAST**

**OF**

**TABERNACLES**

**LAST**

**GREAT**

**DAY**

---

Parents: Tell your child the words may be found written backwards, forwards, up or down.

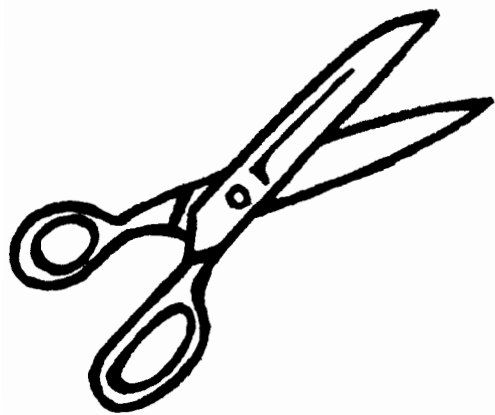

# SCRAPBOOK

---

Parents: Your child may wish to paste postcards, snapshots, etc., on this page and the one to follow.

SCRAPBOOK

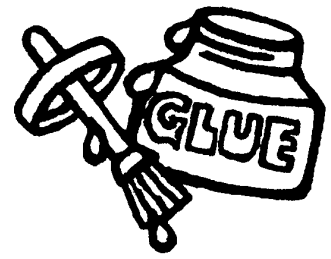



## THE LAST GREAT DAY

The Last Great Day is the last one of God's festivals. It falls on the day right after the last day of the Feast of Tabernacles. This Holy Day shows a time when all those people who died never knowing God's truth will be made alive so they can learn and live God's way as those during the Millennium did. There will be billions and billions of people brought back to life at the beginning of this wonderful time.

This time is called the "Great White Throne Judgment." The Last Great Day is also one of the times during the year when God says to give an offering.

---

**Parents:** Explain that many of your child's grandparents or uncles or aunts who died not in God's Church will be made alive again and will live during this time. They will actually be able to see and talk with them!

# Fulfilling Matthew 24:14 and Matthew 28:19-20



*Continuing Church of God* [www.ccog.org](http://www.ccog.org)  
*Daily Bible News Prophecy* [www.cogwriter.com](http://www.cogwriter.com)

**CCOG.ASIA** This is a website focused on Asia. It has articles in Mandarin Chinese as well as some in English, plus some items in other Asian languages.

**CCOG.EU** This is a website targeted towards Europe. It has materials in many European languages.

**CCOG.IN** This is a website targeted towards those of Indian heritage, and includes materials in Hindi.

**CCOG.NZ** This is a website targeted towards those in New Zealand.

**CCOGCanada.CA** This is a website targeted towards those in Canada.

**CDLIDD.ES** La Continuación de la Iglesia de Dios. This is the Spanish language website for the Continuing Church of God.

**PNIND.PH** Patuloy na Iglesia ng Diyos. This is the Philippines oriented website with items in English and Tagalog.



---

***BibleNewsProphecy channel***  
[www.youtube.com/BibleNewsProphecy](http://www.youtube.com/BibleNewsProphecy)

***ContinuingCOG channel***  
[www.youtube.com/continuingcog](http://www.youtube.com/continuingcog)

***ContinuingCOG Africa channel***  
[www.youtube.com/ccogafrica](http://www.youtube.com/ccogafrica)

---

The *Continuing Church of God* also uses printed and electronic magazines, books, and weekly letters to the brethren to also support Matthew 24:14 and Matthew 28:19-20.